

SELECTIVE SOLDERING MACHINES

CELEBRATING MORE THAN 25 YEARS IN THE AUTOMATED SOLDERING INDUSTRY

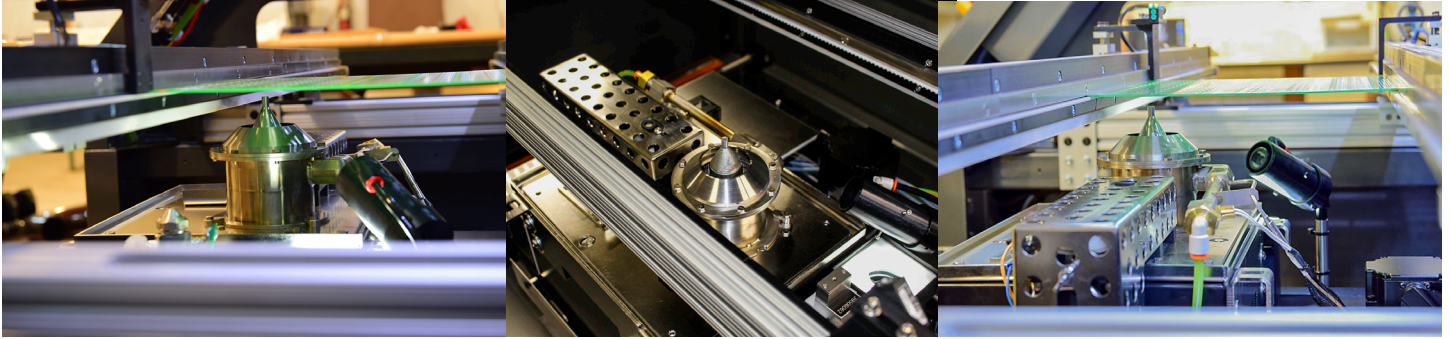

 **HENTEC**
INDUSTRIES

RPS



Proudly made in the USA

SELECTIVE SOLDERING MACHINES

Vector 300

Purpose: PCB Assembly | Miniwave Motion
Price: Entry Level
Solder Pot Capacity: 35lbs | 15.9 kgs
Process Range: 12 x 12" | 300 x 300 mm
Min/Max PCB Size: 1 x 1" to 14 x 18" | 25 x 25 mm to 355 x 457 mm
Footprint: 52 x 49 x 50" (D x L x H)
Features: Servo Motion Control
 Batch Load Standard
 Lead Screw



Vector 460

Purpose: PCB Assembly | Miniwave Motion
Price: Entry-Mid Level
Solder Pot Capacity: 35lbs | 15.9 kgs
Process Range: 18 x 18" | 460 x 460 mm
Min/Max PCB Size: 1 x 1" to 20 x 22" | 25 x 25 mm to 508 x 559 mm
Footprint: 58 x 55 x 50" (D x L x H)
Features: Servo Motion Control
 Batch Load Standard
 Lead Screw



Vector 600

Purpose: Large PCB Assembly | Miniwave Motion
Price: Mid Level
Solder Pot Capacity: 35lbs | 15.9 kgs
Process Range: 24 x 24" | 600 x 600 mm
Min/Max PCB Size: 1 x 1" to 26 x 28" | 25 x 25 mm to 660 x 711 mm
Footprint: 78 x 55 x 50" (D x L x H)
Features: Servo Motion Control
 Batch Load Standard
 Lead Screw



Valence 3508

Purpose: High Volume PCB Assembly | Miniwave Motion
Price: Mid-High Level
Solder Pot Capacity: 25 lbs | 11.4 kgs
Process Range: 20 x 20" | 508 x 508 mm
Min/Max PCB Size: 1 x 1" to 22 x 24" | 25 x 25 mm to 559 x 610 mm
Footprint: 135 x 60 x 60" (D x L x H)
Features: Electromagnetic Pump
 Digital Pyrometer
 Top and Bottom Side Preheat
 Automatic Load | Inline SMEMA
 Continuous Duty Multi-Station
 High Efficiency Ball Screw



STANDARD FEATURES

- Steel welded frame
- Integrated computer | Unlimited programs
- Hentec ConductorPRO™ Software
- Spray or Drop Jet Fluxer
- Low dross/ low maintenance
- Hentec PROHeat™ N2 Independent Temp Control
- Lead free compatible
- LiveView™ Witness Camera
- Fiducial Auto Correct
- 1.5 mm Standard Keep Away (0.5 mm capable)
- UL and CE certified
- Closed Loop Wave Height Sensor
- Two year system warranty
- Four year solder pot warranty

ADDITIONAL STATIONS AND UPGRADES

Vector Series:
 Top Side Preheat
 Conventional Wave Nozzles
 Dual Flux Nozzles
 Custom Nozzles
 SMEMA Inline Operation
 Dual Chemistry Flux
 Extended Warranty

Valence Series:
 Auto Solder Feeder
 2 or 3 Station Configurable

Hentec offers easy-to-use selective soldering systems for miniwave soldering of post reflow through-hole components, and odd form printed circuit board assemblies. The single gantry systems were designed for high mix, mid volume needs, as well as multi-station inline systems for high volume applications. Miniwave nozzles can be easily changed via magnetic coupling. Flux systems can be configured with single or multiple spray and/or high precision drop jet nozzles.

UNMATCHED THERMAL CAPACITY | INCREASED ROI | RAPID PROGRAMMING

Hentec ProHeat™ is a key thermal innovation. Providing closed loop programmable control of independently heated N₂, for miniwave inertion, yields an unmatched thermal efficiency. This unique thermal capacity means the system can be deployed across the widest spectrum of applications, thereby increasing the ROI. Hentec selective soldering systems provide industry leading thermal transfer at the point of soldering. This produces superior solder joints lessening the need for top-side preheat; saving time, money, and reducing the risk for component damage. All Hentec systems are easy to program and operate. The Hentec ConductorPRO™ programming software provides a simple interface for offline or online rapid programming. For example; import a scanned image or Gerber data, select nozzle type and solder points to generate a selective soldering program in just minutes. Hentec ConductorPRO™ is able to store an unlimited number of programs.

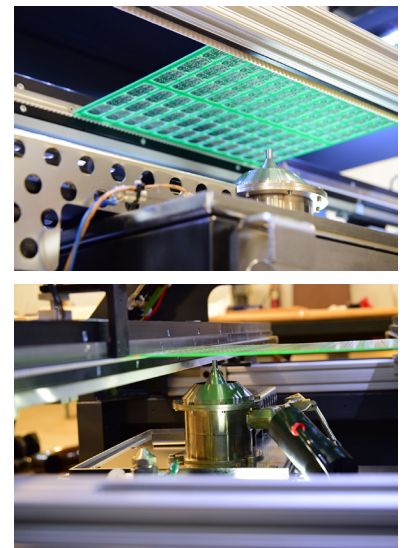

HIGH PRECISION

All Hentec systems come standard with reliable closed loop servo motion control; enabling repeatable and worry-free soldering accuracy. Proprietary pump, nozzle, and control software provide a tall stable miniwave, yielding industry leading 0.5 mm keep aways. The tall stable miniwave can solder leads up to 6 mm long, eliminating the need to trim leads or exclude a project due to long lead length.

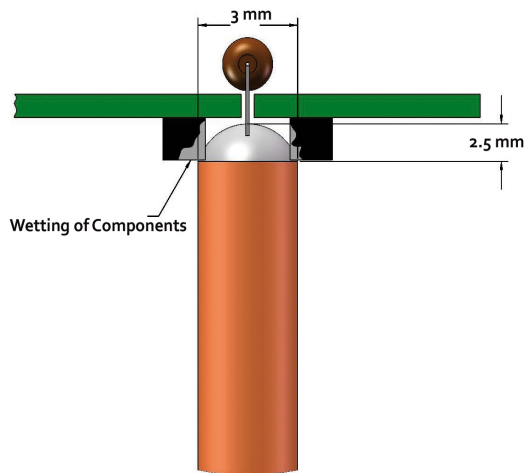

Others

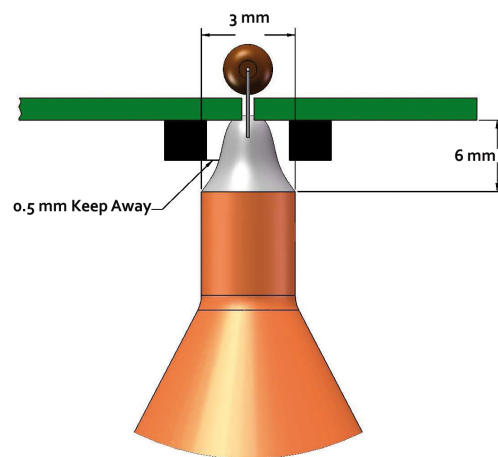

Hentec Advantage

SUCCESS IN THE FIELD

"The versatility of the Hentec selective soldering system is phenomenal. We've processed PCB's from .032" through .100 thick with no problems, and changing to a new PCB process is a breeze."

- Shannon Duffy, Manufacturing Manager at Circle Prime

GLOBAL DISTRIBUTORS: United States, Canada, Australia, Brazil, China, Europe, Mexico, Phillipines, Russia, South Korea, United Kindom, Israel, Italy, France



25517 E Kildea Road Newman Lake, WA, 99025, USA
© Hentec Industries, Inc 2020



website: www.rpsautomation.com
email: sales@rpsautomation.com
phone: 509.891.1680