



Norbro Series 40R Pneumatic Actuator *Double Acting or Spring Return*



Experience In Motion

Flowserve Norbro Series 40R

Since the mid-Sixties the Norbro name has been recognized as the leading quarter turn actuator for industry. As proof of this, Norbro pneumatic actuators can be found in a range of applications as diverse as the petrochemical industry, food and beverage, steel production, pharmaceuticals, plastics manufacturing and oil and gas.

Norbro was the first manufacturer to utilize support rods within the actuator. This ensures that any side loads generated by the pistons are transmitted through bearings in the end cap and not the body. Therefore the bore of the body is only used as a sealing surface and not the bearing surface, hence increasing the life of the actuator. This feature distinguishes the Norbro actuator from the standard rack and pinion design providing reliability, long life and high performance.

The Norbro design also focuses on operational safety, ease of maintenance and a modular design concept which allows simple attachment of a variety of ancillaries to match customer requirements. All of these factors add up to providing you with the finest pneumatic actuator available today.

Features and Benefits

Namur VDI/VDE 3845 top mounting pattern – for easy fitting and interchangeability of switches, positioners, etc

Anodised aluminium construction – for anti-corrosion and superior wear performance on internal surfaces plus stainless steel fasteners and corrosion-protected springs

One piece steel pinion drive with full width piston tooth engagement – for greater operational life

Multi-spring fail-safe concept ensures actuator operation in the unlikely event of spring fracture (spring return models)

For fail-safe operation in a fire, polished support rods retain fire-safe capability even if bearings are fire damaged

Namur VDI/VDE 3845 end-cap solenoid mounting pattern – facilitates interchangeability of solenoids or direct port connections.

Balanced double rack and pinion provides a linear torque curve with a large range of sizes for efficient torque matching

Mounting to the ISO 5211 pattern and DIN 3337 female star drive provides common actuator to valve attachment

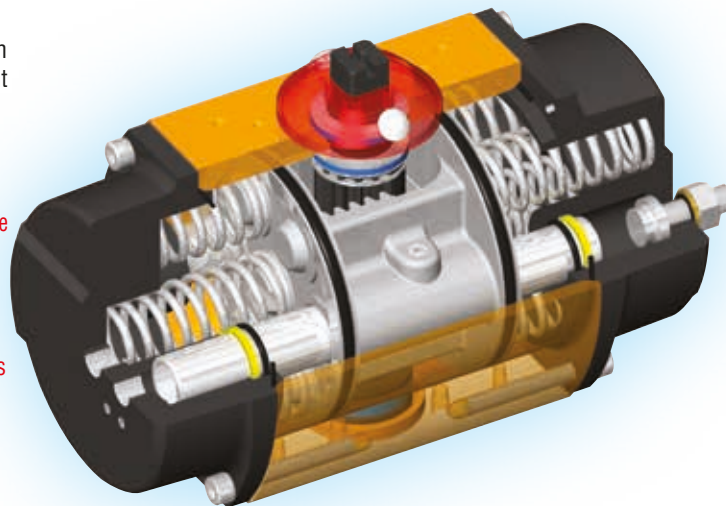

Position indicator – provides external indication of valve position

Foolproof location pin for correct assembly

Compact fail-safe size as per double-acting – minimises space requirements

Blow-out proof pinion – eliminates risk of pinion ejection even after pinion retaining ring is removed

Adjustable limit stops for accurate rotation (See page 5)

Unique unrestricted air flow through support rods gives fast operation speeds as standard – and also provides greater safety (centre chamber cannot be pressurised with end cap removed)

Multi-spring concept – provides variable torque/air pressure requirements from the same actuator by changing spring quantity

Long screws – to allow complete release of spring energy for safe removal of end caps when maintaining / reconfiguring springs without the need for special tooling

Operating Principle

The Norbro 40R pneumatic actuator is based on the opposed double rack and pinion principle but utilises unique support rods to transfer air between the chambers of the actuator and minimise friction and wear between pistons and body bore

Double Acting Actuators

In the double acting model, compressed air is applied to Port 1, which is fed via the large bore support rod into the centre chamber. This forces the pistons apart and turns the actuator's output drive anti-clockwise (seen from above) for valve opening, simultaneously venting the air in the end chambers via the second support rod through Port 2. This operation can be reversed by supplying air into Port 2 for clockwise rotation (valve closing).

Spring Return Actuators

With the fail-safe spring return model, air is applied in a similar way to Port 1 for anti-clockwise operation (valve opening) and the movement of the pistons compresses the springs held in the end chambers of the actuator. This position will be maintained until air pressure is released when the spring force closes the pistons together for clockwise operation (valve closing).

Double Acting Actuators

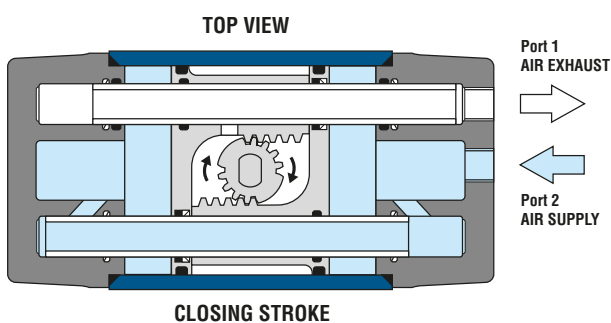
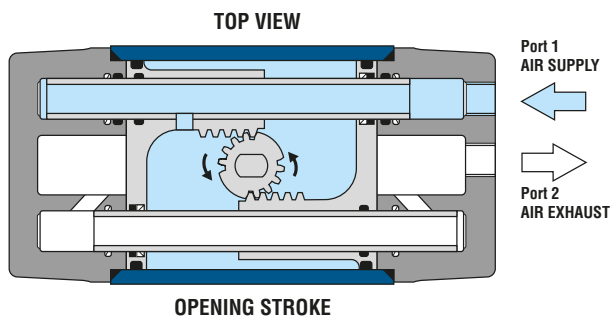

Spring Return Actuators

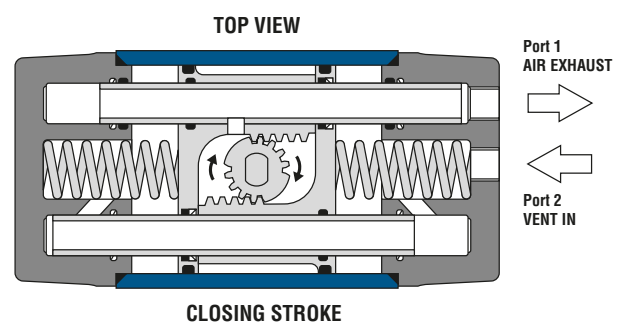
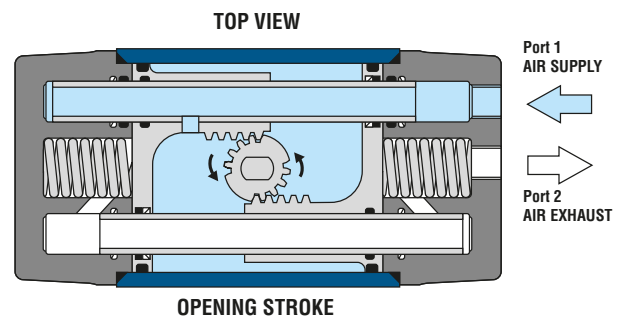

NOTE: With the size 05 actuator, air is supplied and vented through the body of the actuator as its compact size makes the use of support rods impractical.

Parts List/Material Specifications

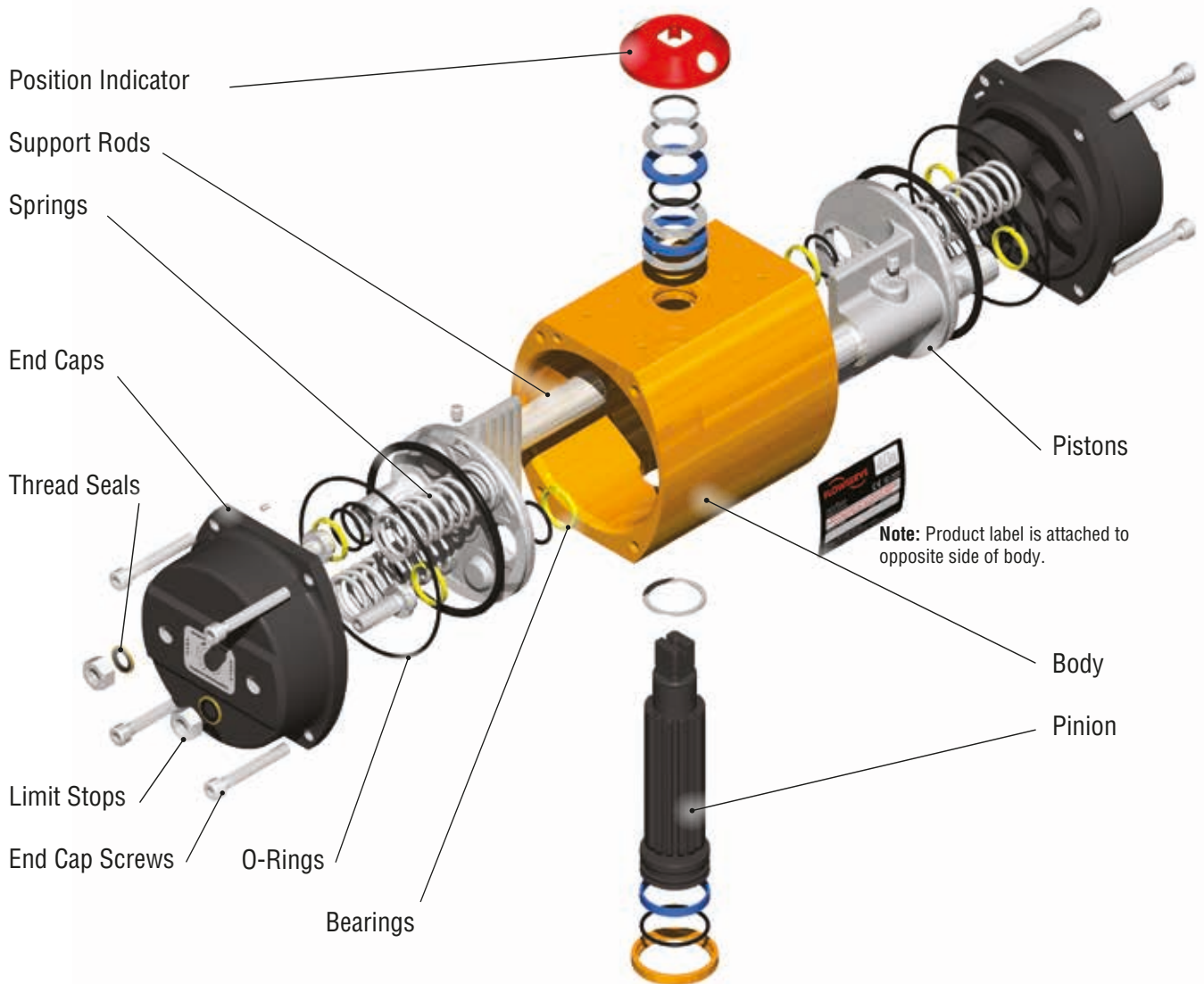

Description	Material/Finish
Body	Aluminium (extrusion) anodised
Pinion	Carbon Steel (corrosion resistant coated)
Pistons	Aluminium
End Caps	Aluminium anodised
Support rods	Stainless Steel
Bearings	Acetal
O-Rings	Nitrile Rubber
End Cap Screws	Stainless Steel
Springs	Chrome Silicon Steel (corrosion resistant coated)
Position Indicator	Polyethylene
Limit Stops	Stainless Steel (Sizes 40 to 50 carbon steel plated)
Thread Seals	Bonded Nitrile and Steel (corrosion resistant coated)



End Mounted Limit Stops

Recognizing the increasing need for accurate rotation adjustment on many applications within the process industry, Flowserve has developed a unique method of providing this feature which is now standard on the actuator.

The design takes advantage of the moving support rods within the actuator and uses two stops in the end cap to limit their travel and therefore adjust the rotation of the actuator in **both directions**.

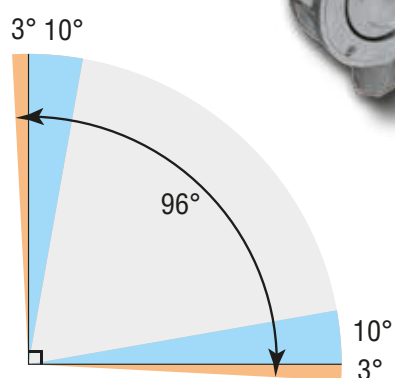

The design allows for a nominal rotation of 96° providing 3° of adjustable over travel at each end of the actuator stroke. The limit stop screws can also be used to adjust the under travel of the actuator by 10° at each end of the actuator stroke.

End Mounted Switch Box

Norbro also offers the J-Switch, end mounted switch box, again taking advantage of the moving support rods to operate switches in an IP66 rated enclosure eliminating the need for mounting brackets and providing a compact design. It also allows the Namur top mounting to be utilised for additional monitoring equipment such as a positioner.

The J-Switch is supplied with a M20 x 1.5p cable entry as standard and has ATEX approved switches that include inductive proximity sensors, explosion proof and gold contacts options.

Note: The J-Switch cannot be used with the limit stop end cap and will be supplied with a 92° rotation actuator.

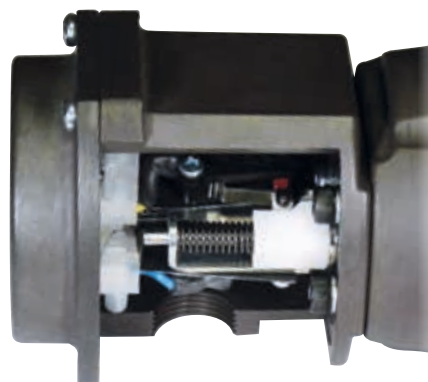

Actuator Sizing

The torque tables detailed below provide actual torque values for the range of actuators at typical pressure and spring configurations. **When sizing a valve, we recommend that a factor of safety is applied to its nominal torque. Please contact Technical Sales for further advice.**

Double Acting Actuators

For a given air supply pressure the double acting actuator provides a linear (constant) torque output throughout its rotation (see chart below).

Torque Output (Nm) – Double Acting Actuator

Size Series	Operating Pressure - bar (g)										
	2.0	2.5	3.0	3.5	4.0	4.5	5.0	5.5	6.0	7.0	8.0
05-40R				7	8	9	10	11	12	14	
10-40R	10	13	16	19	22	25	28	31	34	40	46
15-40R	20	26	31	37	43	49	54	60	66	77	88
20-40R	37	47	57	68	78	89	99	109	120	141	162
25-40R	61	78	96	113	131	148	165	183	200	235	270
30-40R	100	129	157	186	214	243	272	300	329	386	443
33-40R	196	252	308	363	419	475	531	587	643	755	867
35-40R	240	309	377	446	515	583	652	720	789	926	1063
40-40R	383	492	602	711	821	931	1040	1149	1259	1478	1697
42-40R	665	854	1044	1234	1424	1615	1804	1993	2184	2564	2943
45-40	995	1280	1564	1847	2133	2418	2701	2984	3270	3840	4407
50-40	1539	1979	2419	2858	3299	3740	4179	4617	5058	5940	6818

Spring Return Actuators

The torque output of a spring return actuator declines throughout its rotation and therefore for both the spring and air stroke we specify a 'start' and 'end' torque. For air pressures below 5 bar (g) the number of springs used in the actuator may need to be reduced to 'balance' the torque output of the spring stroke and air stroke.

When sizing spring return actuators it is important that the actuator has sufficient torque to open and close the valve. The table below shows the actuator torque related to the position of the valve for both fail closed (standard) and fail open operation.

Valve Position	Actuator Operation	
	Spring to Close	Spring to Open
Break out from closed position	Air stroke - Start	Spring stroke - Start
Break in to open position	Air stroke - End	Spring stroke - End
Break out from open position	Spring stroke - Start	Air stroke - Start
Break in to closed position	Spring stroke - End	Air stroke - End

Torque Output (Nm) – Spring Return Actuator

Figures shown in blue shaded cells provide the optimum torque match between air stroke and spring stroke.

Size Series	No. Springs	Spring Stroke		Air Stroke																	
				2.5 bar (g)		3.0 bar (g)		3.5 bar (g)		4.0 bar (g)		4.5 bar (g)		5.0 bar (g)		5.5 bar (g)		6.0 bar (g)		7.0 bar (g)	
		Start	End	Start	End	Start	End	Start	End	Start	End	Start	End	Start	End	Start	End	Start	End	Start	End
05-40R	2	4.7	3.6					3.2	1.9	4.1	2.8	5.1	3.7	6.1	4.6						
	4	6	4.6											5.1	3.4	6	4.2	7	5.1		
10-40R	4	8	5	9	6	12	8														
	6	12	7			10	5	12	7	15	10										
	8	16	10							13	6	16	9	18	11						
15-40R	10	20	12											16	8	19	10	22	13	27	18
	4	13	8	18	13	24	18														
	6	20	13			20	12	25	17	30	22										
20-40R	8	26	17							26	16	31	21	37	26						
	10	33	21											33	20	38	25	43	30	54	40
	4	24	15	34	24	43	33														
25-40R	6	36	24			36	22	46	31	55	40										
	8	47	31							48	29	57	38	67	48						
	10	59	38									50	27	59	36	69	46	79	55	99	73
30-40R	4	43	26	55	37	72	52														
	6	64	39			59	32	75	47	91	63										
	8	86	53							78	43	94	58	111	73						
33-40R	10	107	66											98	53	114	69	130	84	163	115
	4	69	42	92	62	119	87														
	6	103	63			98	54	125	80	151	105										
35-40R	8	138	84							130	72	157	98	184	123						
	10	172	105											163	91	190	116	217	141	270	192
	4	142	91	171	113	224	163														
40-40R	6	213	136			178	96	231	145	283	195										
	8	284	182							238	127	290	177	343	226						
	10	356	227											297	159	250	209	402	258	510	357
42-40R	4	164	105	217	149	281	210														
	6	246	158			228	132	293	193	357	254										
	8	328	210							304	176	369	237	433	298						
45-40	10	410	263											381	220	445	281	509	342	638	463
	4	281	169	345	219	447	316														
	6	421	253			363	184	465	281	568	377										
50-40	8	562	337							483	245	586	342	689	439						
	10	702	422											604	306	707	403	810	500	1015	694
	4	496	293	598	372	776	540														
50-40	6	744	439			629	306	807	474	985	642										
	8	992	585							839	408	1017	576	1195	744						
	10	1240	731											1049	510	1227	678	1404	846	1761	1182
	8	690	357	976	607	1242	859														
50-40	12	1035	535			1064	532	1330	785												
	16	1380	714					1152	459	1419	711	1685	962								
	20	1725	892									1507	636	1773	888	2040	1140				
	24	2070	1071											1595	562	1861	814	2128	1066	2661	1569
50-40	8	1090	552	1510	918	1923	1307														
	12	1635	827			1647	793	2059	1182												
	16	2180	1103					1783	667	2196	1057	2608	1446								
	20	2725	1379									2332	931	2745	1321	3157	1710				
50-40	24	3270	1654											2469	806	2881	1196	3294	1585	4119	2364

Dimensions Size 10 to 50 40R/40 (mm)

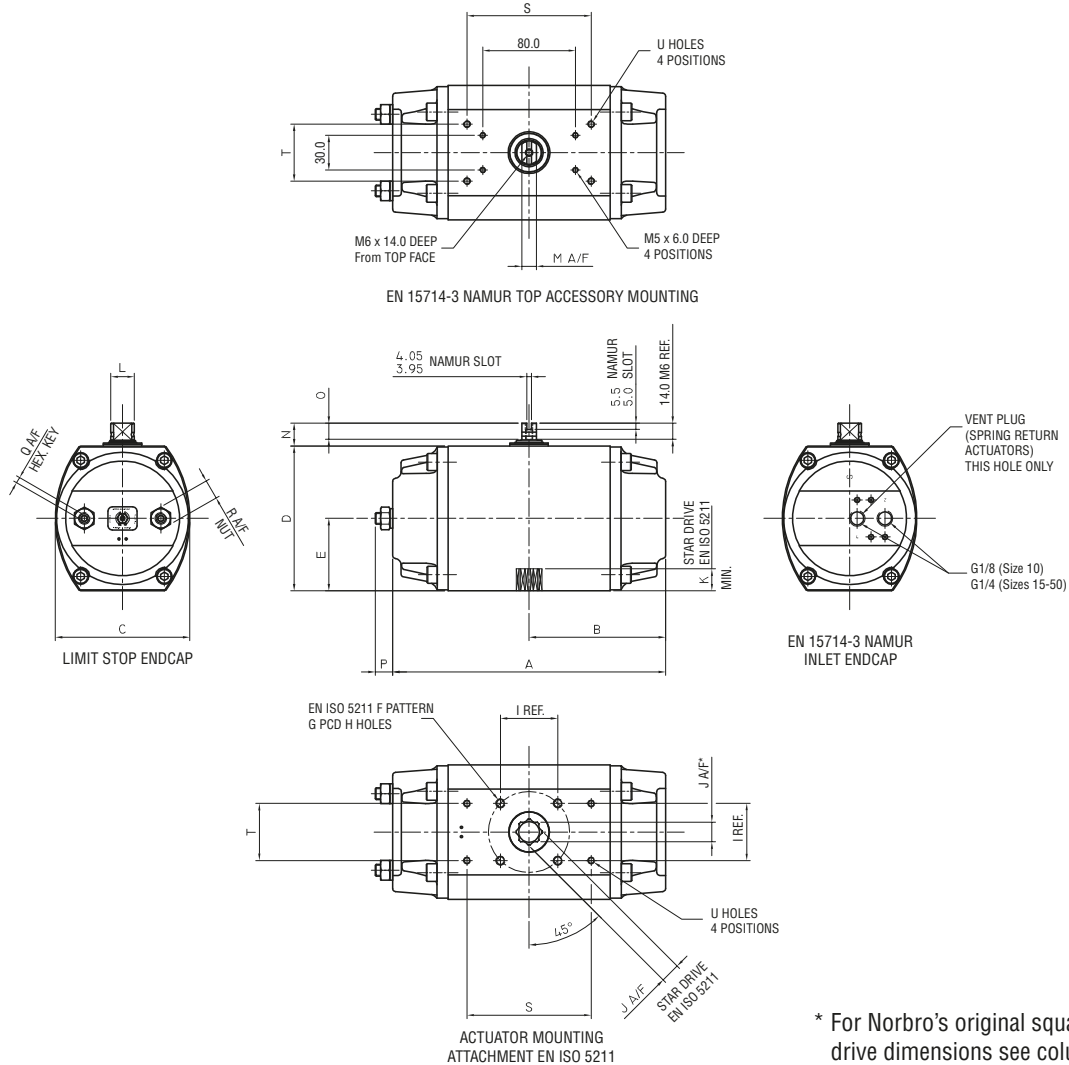

* For Norbro's original square female drive dimensions see column V.

Size Series	Basic Dimensions					Bottom ISO Mounting Dimensions						Top Pinion Dimensions				Limit Stop Dimensions			Ancillary Hole Dimensions (Note 2)			*
	A	B	C	D	E	F	G	H	I	J	K	L	M	N	O	P	Q	R	S	T	U	
10-40R	155.3	77.7	76.8	85.5	42.8	F04	42.0	M5 x 0.25 6.25 DP	29.7	11.11 11.00	12.0	15.0	9.0	20.0	16.0	10.0	4.0	13.0	73.0	31.8	M5 x 0.25 6.3 DP	11.23 11.10
15-40R	195.3	97.7	94.0	104.0	52.0	F05	50.0	M6 x 0.30 7.5 DP	35.4	14.11 14.00	16.0	16.0	12.6	20.0	13.9	11.0	4.0	13.0	73.0	31.8	M5 x 0.24 6.0 DP	14.40 14.27
20-40R	235.4	117.7	116.0	125.0	62.5	F07	70.0	M8 x 0.40 10.0 DP	49.5	17.11 17.00	19.0	20.3	12.6	20.0	13.8	15.0	5.0	17.0	107.2	49.2	M6 x 0.27 7.0 DP	14.40 14.27
25-40R	271.0	135.5	135.5	146.6	73.5	F07	70.0	M8 x 0.40 10.0 DP	49.5	17.11 17.00	19.0	19.0	19.0	30.0	22.2	21.0	6.0	19.0	107.2	49.2	M6 x 0.4 10.0 DP	19.18 19.05
30-40R	325.1	162.6	155.0	167.5	83.8	F10	102.0	M10 x 0.50 12.5 DP	72.1	22.13 22.00	24.0	22.1	22.1	30.0	21.9	23.0	6.0	19.0	161.1	73.0	M6 x 0.4 10.0 DP	19.18 19.05
33-40R	398.7	199.4	206.0	214.0	107.0	F12	125.0	M12 x 0.70 18.0 DP	88.4	27.13 27.00	29.0	28.5	28.5	30.0	21.2	23.0	8.0	24.0	161.1	86.0	M8 x 0.5 13.0 DP	25.53 25.40
35-40R	423.9	212.0	213.0	217.0	108.5	F12	125.0	M12 x 0.63 16.0 DP	88.4	27.13 27.00	29.0	28.5	28.5	30.0	20.9	30.0	8.0	24.0	212.7	101.6	M8 x 0.6 14.0 DP	25.53 25.40
40-40R	511.8	255.9	244.9	276.0	149.0	F14	140.0	M16 x 0.95 24.0 DP	99.0	36.16 36.00	40.0	34.9	34.9	50.0	37.0	27.0	10.0	30.0	243.6	117.5	M10 x 0.6 15.0 DP	28.70 28.57
42-40R	619.7	309.9	283.0	316.0		F16	165.0	M20 x 1.20 30.0 DP	116.7	46.16 46.00	50.0	50.8	50.8	50.0	34.5	30.0	10.0	30.0	133.4	101.6	M8 x 0.5 13.0 DP	46.16 46.00
45-40	575.9	288.0	334.9	373.5	203.0	F16	165.0	M20 x 1.20 30.0 DP	116.7	46.16 46.00	48.0	50.8	50.8	50.0	34.5	28.0	10.0	30.0	330.2	158.7	M16 x 0.95 24.0 DP	44.60 44.45
50-40	626.0	313.0	387.5	424.2	227.4	F25	254.0	M16 x 0.95 24.0 DP	Note 1	55.19 55.00	57.0	57.0	57.0	50.0	32.8	35.0	10.0	30.0	243.7	117.5	M10 x 0.6 15.0 DP	44.60 44.45

Note 1: Model 50-40 uses 8 mounting holes on PCD distributed evenly about the center lines of the actuator.

Note 2: On sizes 42, 45 and 50 ancillary mounting holes are only on the top of the actuator and on size 40, only on the base. These sizes also have a location spigot on the base of the actuator in accordance with ISO 5211.

Dimensions Size 05 40R (mm)

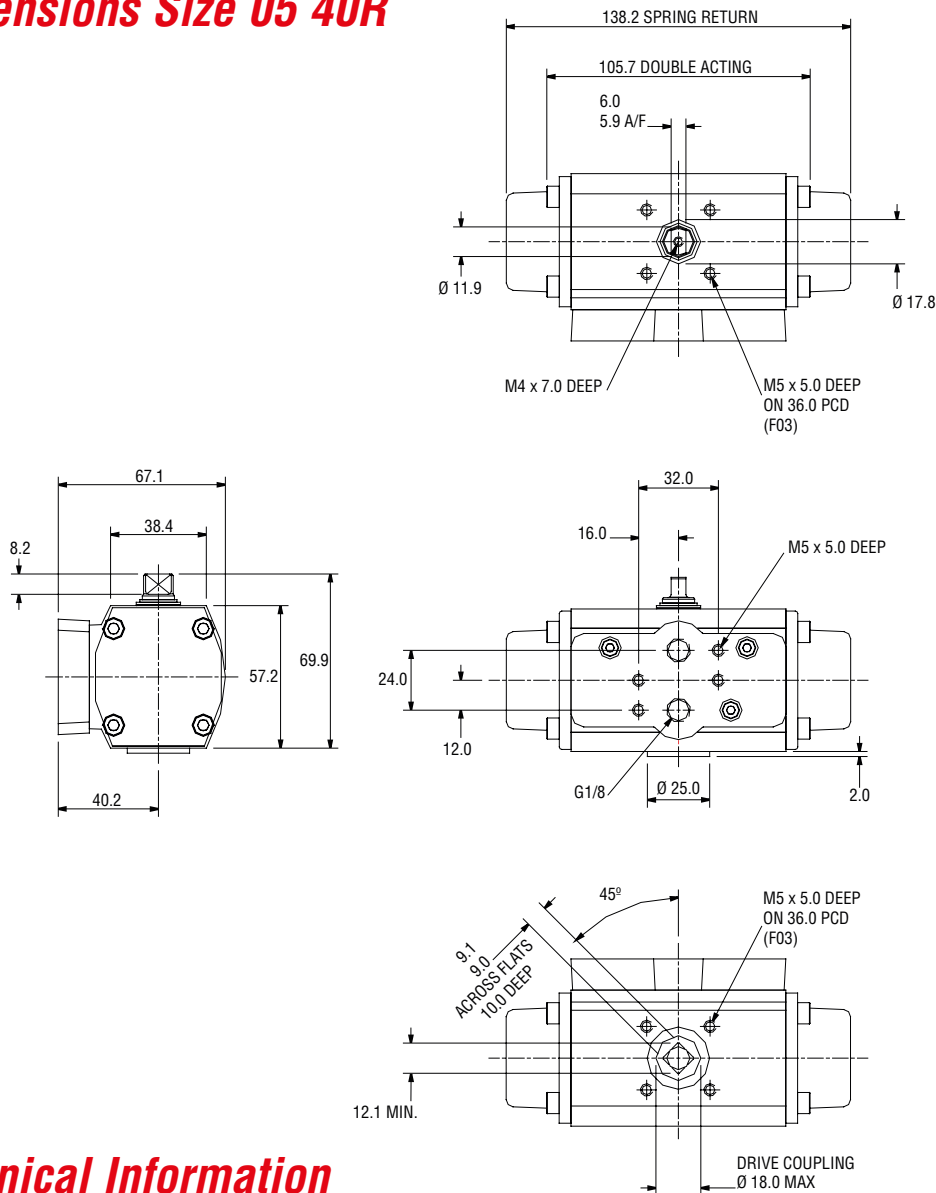

Technical Information

Size / Series	Operating Speed (Seconds) Actuator with no load using Namur solenoid at 5.5 bar (g)			Actuator Free Internal Volume (Litres)		Weight (Kg)	
	Double Acting	Spring Return (Open)	Spring Return (Close)	Open	Close (DA Only)	Double Acting	Spring Return
05-40R	0.10	0.10	0.10	0.05	0.05	0.7	0.8
10-40R	0.15	0.15	0.15	0.17	0.22	1.3	1.6
15-40R	0.3	0.3	0.3	0.35	0.39	2.7	3.1
20-40R	0.5	0.5	0.5	0.69	0.74	4.5	5.5
25-40R	0.6	0.6	0.6	1.22	1.31	7.4	8.4
30-40R	1.1	1.4	1.0	1.86	2.05	11.0	12.0
33-40R	2.1	2.7	1.7	3.39	4.79	22.5	26.0
35-40R	2.9	3.2	2.2	3.93	5.54	26.0	30.0
40-40R	3.0	4.5	3.5	6.73	8.19	43.6	48.6
42-40R	7.0	8.0	4.6	12.00	13.89	71.8	80.6
45-40	9.0	12.0	6.8	13.51	20.00	97.0	115.0
50-40	19.0	24.0	10	23.87	30.50	138.0	161.0

- Notes**
- Speeds other than those given above are obtainable if required by using additional control equipment. **NOTE:** These times for the actuator are typical and can vary under actual operating conditions. They are given as a guide only
 - To obtain Free Air Displacement (FAD) Volume, multiply actual volumes by the absolute working pressure, bar (a). The figures in the table above are also the hydraulic volume.

Additional Information

Working Pressure	8.3 bar (g) Maximum. For higher pressures contact our sales office.
Media	Air or non-corrosive fluid
Temperature range	Standard -20°C to +100°C Low temperature variant -40°C to +85°C* High temperature variant -20°C to +150°C
Operation (viewed from the top)	Pinion rotates anti-clockwise when the centre chamber supply port 1 is pressurised (see Page 3)
ATEX	Conforms to ATEX 94/9/EC under equipment group II, category 2 (non-mining)
SIL	Certified to IEC61508 to SIL level 3 capability

* Please contact Technical Sales for options down to -40°C

<p>Rotation</p> <p>Non Limit Stop:</p> <ul style="list-style-type: none"> Nominal 92° total travel including nominal 1° over travel both clockwise and anti-clockwise. <p>Limit Stop:</p> <ul style="list-style-type: none"> Nominal 96° total travel including nominal 3° adjustable overtravel and adjustable 10° undertravel both clockwise and anti-clockwise. <p>Special:</p> <ul style="list-style-type: none"> 180°, 120° - Series 33. For further options consult the Sales Office.
<p>Mounting Configurations</p> <p>Solenoid:</p> <ul style="list-style-type: none"> EN15714-3 VDI/VDE 3845 mounting pattern <p>Top Mount Interface:</p> <ul style="list-style-type: none"> EN15714-3 VDI/VDE 3845 mounting pattern <p>Actuator/Valve Interface:</p> <ul style="list-style-type: none"> Standard - ISO 5211 pattern with DIN3337 Star drive pinion (female) Norbro original - ISO 5211 with Norbro square drive pinion (female)

Basic Coding on Norbro 40R Pneumatic Actuators

(For full details of 40R coding and 40 Series coding please contact Technical Sales)

Size		1	2	3	4	5	6	7	8	9	10	11	12	13	14	15	16	17
				Rotation	Body	Function	Product Series			Finish	Temperature	Inlet Endcap	Limit Stop / Switch Endcap	Pinion	Options		Revision	
Digits - 1, 2		Digit 4 - Rotation			Digits - 7, 8 Series			Digit - 11 Temperature			Digits - 14 Pinion							
05 Size 05	R	92° Std / 96° Limit Stop			40	40R Actuator		S	Standard -20°C to +100°C			E	Norbro square - Female					
10 Size 10	Digit 5 - Body				Digit 10 - Finish			H	High -20°C to +150°C			N	Star drive ISO/DIN - Female					
15 Size 15	D	Standard with ISO ring			1	Standard Anodised		L	Low -40°C to 85°C			Digit 15 - Options						
20 Size 25	K	Standard w/o ISO ring			2	Epoxy Coated		Digit 12 - Inlet Endcap			0	Standard						
25 Size 25	Digit 6 - Function				3	PVC Coated		A	Namur pattern NPT ports			H	Hydraulic					
30 Size 30	A	Double Acting						D	Namur pattern BSPP ports			Digit 17 - Revision						
33 Size 33	B	Spring Return 10 Springs						S	Fast acting									
35 Size 35	C	Spring Return 8 Springs						Digit 13 - Limit stop/Switch E'cap										
40 Size 40	D	Spring Return 6 Springs						1	J Switch									
42 Size 42	E	Spring Return 4 Springs						B	Blank									
	F	Spring Return 2 Springs (size 05 actuator only)						0	Blank (05 Actuators)									
								M	Limit stop 10 to 35									
								T	Limit stop 40 to 42									

Example: Size 20 with ISO ring Double Acting, Anodised Body, Standard Temperature, Namur Inlet Endcap and Limit Stop End cap with Star Drive Pinion

2	0	-	R	D	A	4	0	-	1	S	D	M	N	0	-	D
---	---	---	---	---	---	---	---	---	---	---	---	---	---	---	---	---

Special Options

Finishes

The Norbro actuator is available in a variety of special finishes to meet specific application needs. The NorGuard coating provides a special anodised finish for enhanced protection in highly corrosive or salt water atmospheres. Flowserve also offer epoxy paint finishes and colours to customer requirements.



NorGuard



Epoxy Paint

Fast Acting

A fast acting version can be achieved by providing direct air feed to the centre chamber and adding dump valves for air exhaust. On sizes 40 to 50 a large Namur solenoid can be specified and mounted to the end cap.

Series 33R 180 Degree Operation

The Series 33R provides 180 degree or 120 degree rotation for use on diverter or damper applications. It utilises the standard Norbro body and end caps but with unique pistons and pinion that are designed to provide the additional rotation within the standard body. This also enables the standard springs to be used providing a fail-safe option.





Flowserve Flow Control (UK)
Burrell Road
Haywards Heath
West Sussex United Kingdom RH16 1TL
Phone: +44 1444 314400
Fax: +44 1444 314401

FCD NBENBR0003-02-A4 06/17

Contact:

For more information about Flowserve Corporation, visit www.flowserve.com or call USA 1-800-225-6989.

Flowserve Corporation has established industry leadership in the design and manufacture of its products. When properly selected, this Flowserve product is designed to perform its intended function safely during its useful life. However, the purchaser or user of Flowserve products should be aware that Flowserve products might be used in numerous applications under a wide variety of industrial service conditions. Although Flowserve can (and often does) provide general guidelines, it cannot provide specific data and warnings for all possible applications. The purchaser/user must therefore assume the ultimate responsibility for the proper sizing and selection, installation, operation, and maintenance of Flowserve products. The purchaser/user should read and understand the Installation Operation Maintenance (IOM) instructions included with the product, and train its employees and contractors in the safe use of Flowserve products in connection with the specific application.

While the information and specifications contained in this literature are believed to be accurate, they are supplied for informative purposes only and should not be considered certified or as a guarantee of satisfactory results by reliance thereon. Nothing contained herein is to be construed as a warranty or guarantee, express or implied, regarding any matter with respect to this product. Because Flowserve is continually improving and upgrading its product design, the specifications, dimensions and information contained herein are subject to change without notice. Should any question arise concerning these provisions, the purchaser/user should contact Flowserve Corporation at any one of its worldwide operations or offices.

© 2015 Flowserve Corporation, Irving, Texas, USA. Flowserve and Norbro are registered trademarks of Flowserve Corporation.

Norbro **Series 40R Pneumatic Actuator** Double Acting or Spring Return (Fail Safe)



Flowserve Norbro Series 40R

Since the mid-Sixties the Norbro name has been recognised as the leading quarter turn actuator for industry.

As proof of this, Norbro pneumatic actuators can be found in a range of applications as diverse as the petrochemical industry, food and beverage, steel production, pharmaceuticals, plastics manufacturing and oil and gas.

From the very beginning Norbro has been dedicated to providing high performance actuators which combine reliability, long life and ease of maintenance with operational safety and a modular design concept which allows simple attachment of a variety of ancillaries to match customer requirements.

With the latest design of the Norbro Series 40R, all of these factors add up to providing you with the finest pneumatic actuator available today.

Namur (VDI/VDE 3845) top mounting pattern – for easy fitting and interchangeability of switches, positioners, etc

Anodised aluminium construction – for anti-corrosion and superior wear performance on internal surfaces

Stainless steel fastenings and anodised externals – improved aesthetics and ease of maintenance

One piece steel pinion drive with full width piston tooth engagement – for greater operational life

Multi-spring failsafe concept ensures actuator operation in the unlikely event of spring fracture (spring return models)

Piston support rods with six bearings minimise internal wear and maximise performance life

Namur (VDI/VDE 3845) end-cap solenoid mounting pattern – facilitates interchangeability of solenoids or direct port connections.

Balanced double rack & pinion – linear torque curve

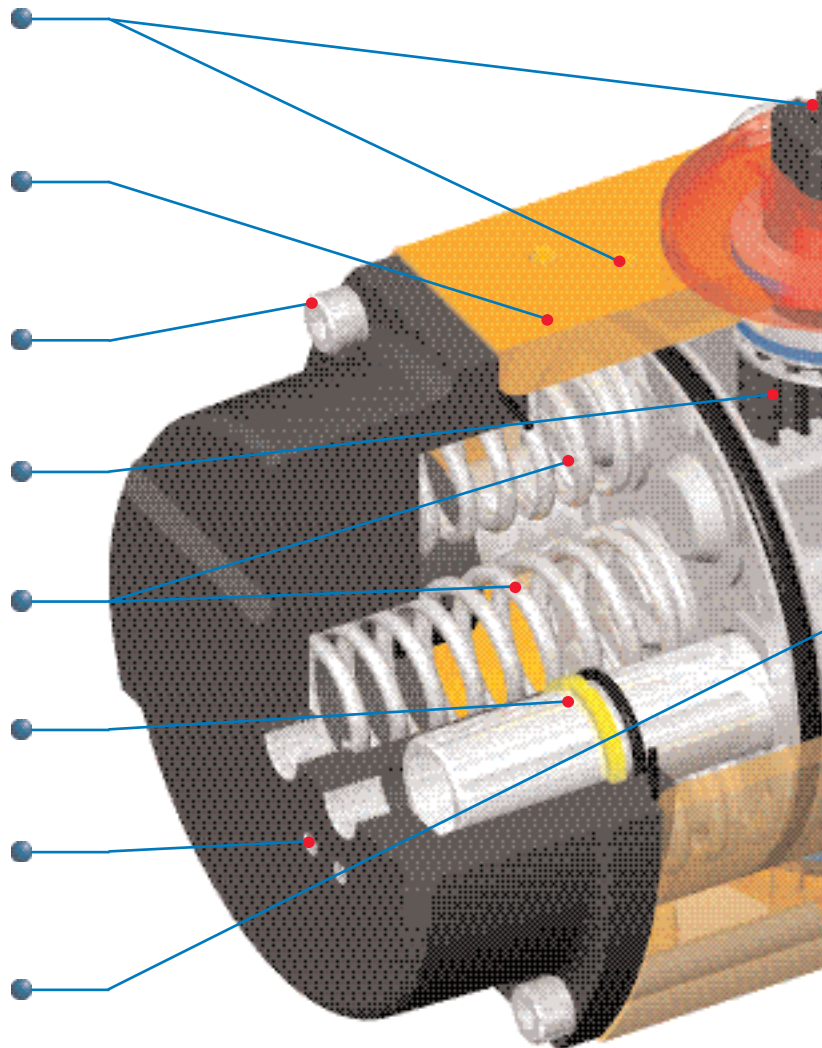

Other Features and Benefits

- Large range of sizes
- Failsafe operation in a fire
- Option for reversible direction of operation
- No special tools required for maintenance
- Standard operating temperature range of -20°C to +100°C
- All parts sealed and greased for life
- For more efficient torque matching
- Polished support rods retain fire-safe capability even if bearings are fire damaged
- For failsafe open capability on butterfly valves
- Simple to maintain
- Increased applications
- No lubricated air supply required

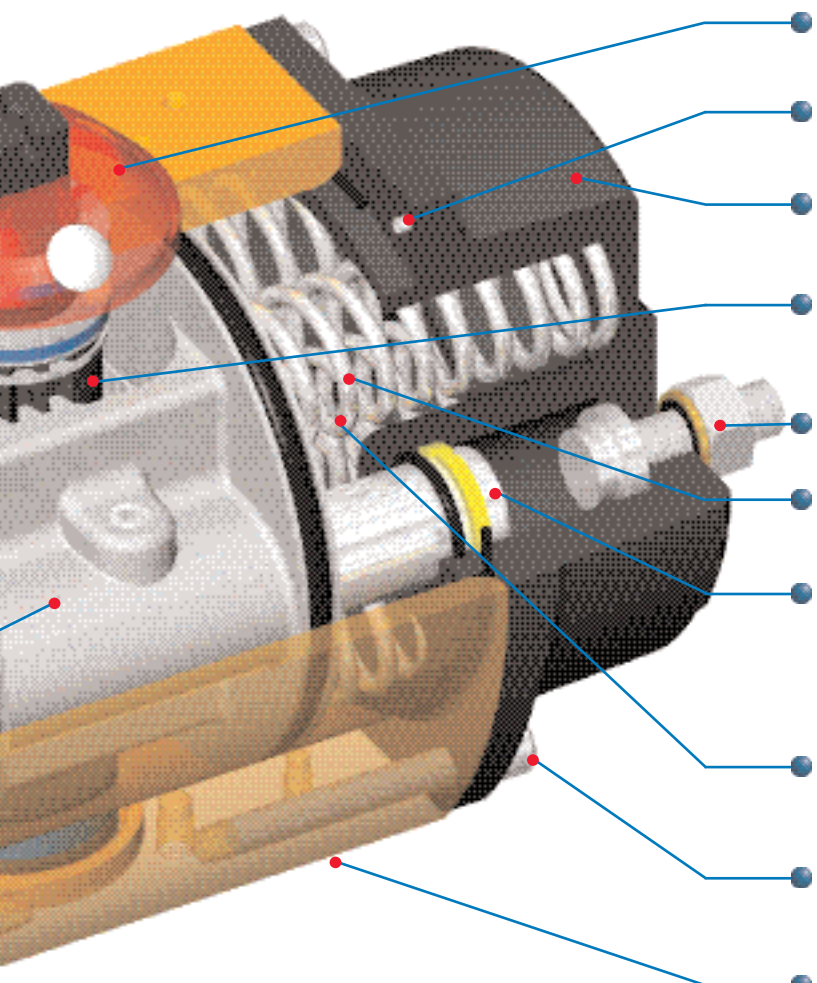

● Position indicator – provides external indication of valve position

● Foolproof location pin for correct assembly

● Compact failsafe size as per double-acting – minimises space requirements

● **Blow-out proof pinion – eliminates risk of pinion ejection even after pinion retaining ring is removed**

● Limit Stops (page 5)

● Corrosion protected springs – for long service life

● Unique unrestricted air flow through support rods gives fast operation speeds as standard – **and also provides greater safety (centre chamber cannot be pressurised with end cap removed)**

● Multi-spring concept – provides variable torque/air pressure requirements from the same actuator by changing spring quantity

● **Long screws – to allow complete release of spring energy for safe removal of end caps when maintaining / reconfiguring springs**

● Mounting to the ISO 5211 pattern allows for interchangeability of mounting kits.



Norbro Original Standard

For nearly 50 years the NORBRO Rack & Pinion actuator has been the by-word for high performance pneumatic actuators.

Its reliability, construction quality and ease of maintenance have established the 40R as the world's leading quarter turn actuator. If the requirement is long life, ease of use and 'fit & forget', then the solution is NORBRO.

In addition, its modular design, allowing simple attachment of a variety of ancillaries (e.g. solenoids, switches, sensors etc), has made it the actuator against which all others are measured.

The NORBRO actuator conforms to all the latest standards as detailed in this publication.

The NORBRO without limit stops can be retrofitted without bracket changes to replace the original NORBRO of 50 years ago. The limit stop version (with the latest international drive dimensions) is readily available as detailed opposite.



Norbro's original rack and pinion actuator was the basis for all subsequent designs.



Norbro IS05211 European with limit stops

Recognising the increasing need for accurate rotation adjustment on many applications within the process industry, Norbro have developed a unique method of providing this feature and it is now standard on the European (excluding UK) version of the actuator.

The design takes advantage of the moving support-rods within the actuator and uses two stops in the endcap to limit their travel and therefore adjust the rotation of the actuator in both directions.

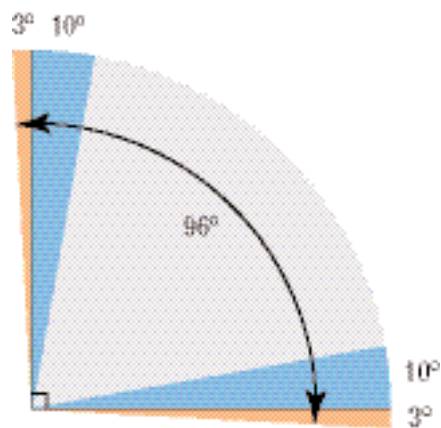

The design allows for a nominal rotation of 96° providing 3° of adjustable over travel at each end of the actuator stroke. The limit stop screws can also be used to adjust the under travel of the actuator by 10° at each end of the actuator stroke.

NOTE: The limit stop will only be supplied as standard on the 40R Series, sizes 10 to 42. For 40 Series, sizes 45 and 50, please contact our Technical Sales Office.



Operating Principle

The Norbro 40R pneumatic actuator is based on the opposed double rack and pinion principle utilising piston support rods to minimise friction and wear between pistons and body bore and transfer air between the chambers of the actuator.

Double Acting Actuators

In the double acting model, compressed air is applied to Port A, which is fed via the large bore support rod into the centre chamber. This forces the pistons apart and turns the actuator's output drive anti-clockwise (seen from above) for valve opening, simultaneously venting the air in the end chambers via the second support rod through Port B. This operation can be reversed by supplying air into Port B for clockwise rotation (valve closing).

Spring Return Actuators

With the fail-safe spring return model, air is applied in a similar way to Port A for anti-clockwise operation (valve opening) and the movement of the pistons compresses the springs held in the end chambers of the actuator. This position will be maintained until air pressure is released when the spring force closes the pistons together for clockwise operation (valve closing).

NOTE: With the size 05 actuator, air is supplied and vented through the body of the actuator as its compact size makes the use of support rods impractical.

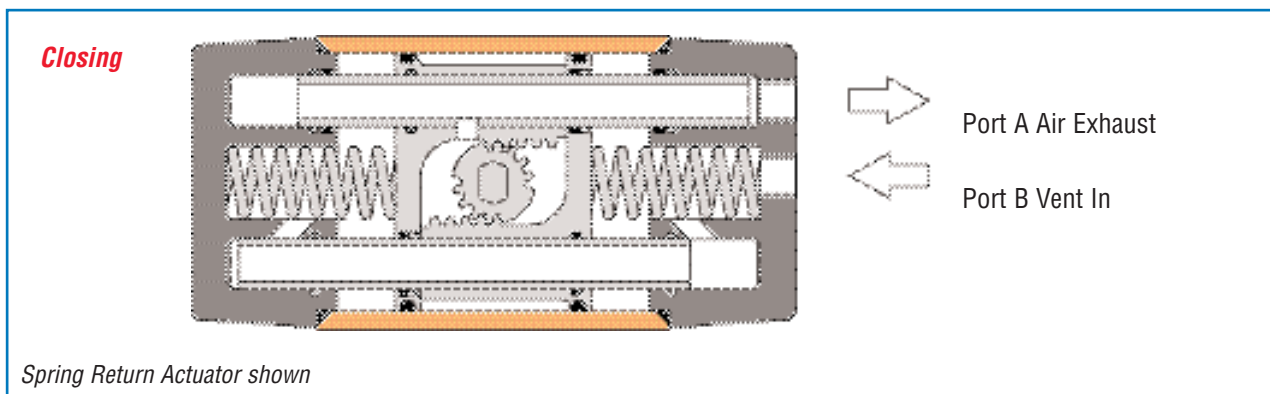
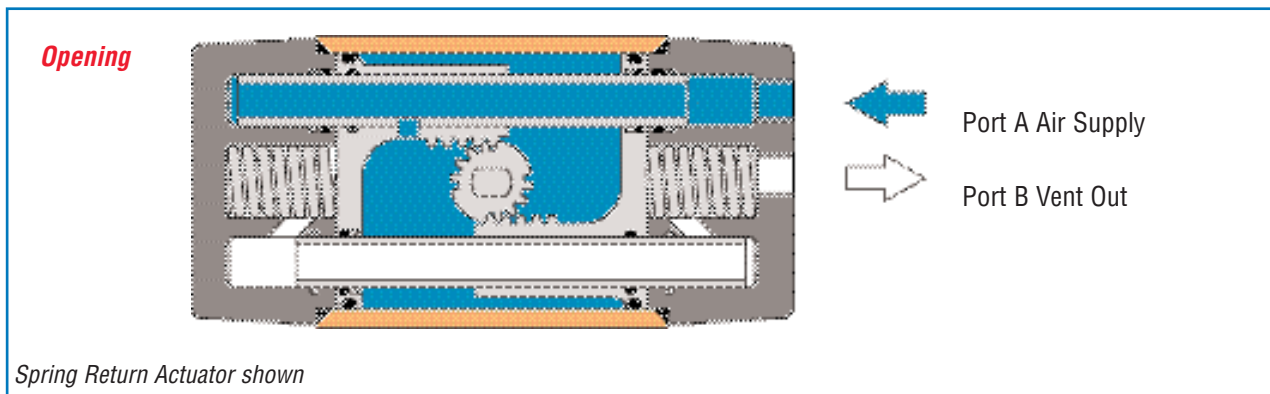

Parts & Materials

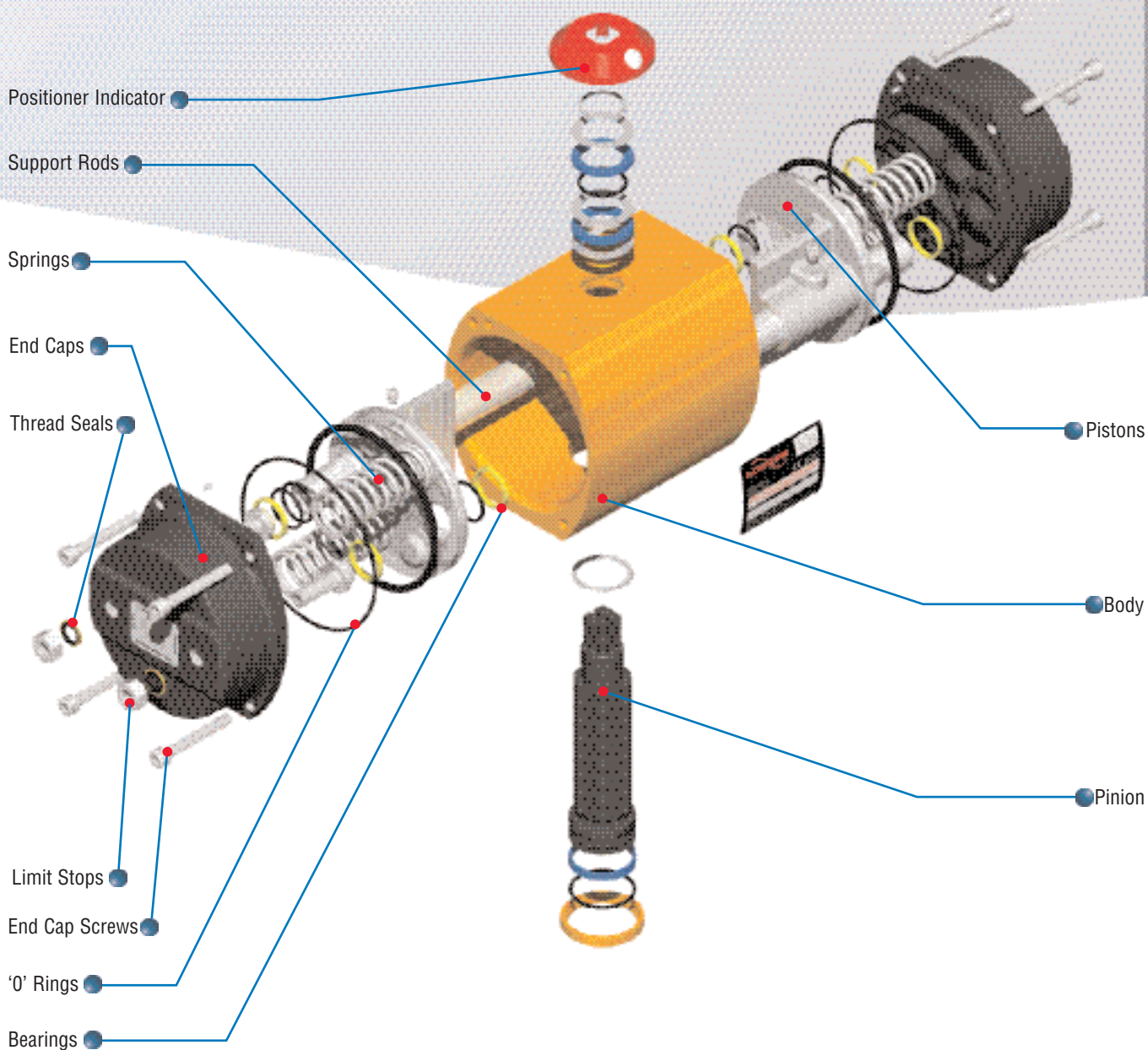

Parts List / Materials Specification

Description	Material/Finish	Description	Material/Finish
Body	Aluminium (Extrusion) Anodised	'O' Rings	Nitrile Rubber
Pinion	Carbon Steel (corrosion resistant coated)	End Cap Screws	Stainless Steel
Pistons	Aluminium	Springs	Chrome Silicon Steel (corrosion resistant coated)
End Caps	Aluminium Anodised	Position Indicator	Polyethylene
Support Rods	Stainless Steel	Limit Stops	Stainless Steel
Bearings	Acetal	Thread Seals	Bonded Nitrile and steel (Corrosion Resistant coated)



Actuator Sizing

When sizing a valve, we recommend that a factor of safety is applied to its nominal torque. Please contact technical sales for further advice.

The torque tables detailed below provide actual torque values for the range of actuators at typical pressure and spring configurations. For more comprehensive sizing calculations the Norbro sizing program should be used (available on request).

Double Acting Actuators

For a given air supply pressure the double acting actuator provides a linear (constant) torque output throughout its rotation (see chart below).

Torque Output (Nm) – Double Acting Actuator

Size-Series	Operating Pressure - bar (g)										
	2.0	2.5	3.0	3.5	4.0	4.5	5.0	5.5	6.0	7.0	8.0
05-40R				7	8	9	10	11	12	14	
10-40R	10	13	16	19	22	25	28	31	34	40	46
15-40R	20	26	31	37	43	49	54	60	66	77	88
20-40R	37	47	57	68	78	89	99	109	120	141	162
25-40R	61	78	96	113	131	148	165	183	200	235	270
30-40R	100	129	157	186	214	243	272	300	329	386	443
33-40R	196	252	308	363	419	475	531	587	643	755	867
35-40R	240	309	377	446	515	583	652	720	789	926	1063
40-40R	383	492	602	711	821	931	1040	1149	1259	1478	1697
42-40R	665	854	1044	1234	1424	1615	1804	1993	2184	2564	2943
45-40	995	1280	1564	1847	2133	2418	2701	2984	3270	3840	4407
50-40	1539	1979	2419	2858	3299	3740	4179	4617	5058	5940	6818

Spring Return Actuators

The torque output of a spring return actuator declines throughout its rotation and therefore for both the spring and air stroke we specify a 'start' and 'end' torque. For air pressures below 5 bar (g) the number of springs used in the actuator may need to be reduced to 'balance' the torque output of the spring stroke and air stroke.

When sizing spring return actuators it is important that the actuator has sufficient torque to open and close the valve. The table below shows the actuator torque related to the position of the valve for both fail closed (standard) and fail open operation.

Valve Position	Actuator Operation	
	Fail Closed	Fail Open
Break out from closed position	Air stroke - Start	Spring stroke - Start
Break in to open position	Air stroke - End	Spring stroke - End
Break out from open position	Spring stroke - Start	Air stroke - Start
Break in to closed position	Spring stroke - End	Air stroke - End

Torque Output (Nm) – Spring Return Actuator

Size-Series	Number of Springs	Spring Stroke		Air Stroke																	
				2.5 bar (g)		3.0 bar (g)		3.5 bar (g)		4.0 bar (g)		4.5 bar (g)		5.0 bar (g)		5.5 bar (g)		6.0 bar (g)		7.0 bar (g)	
		Start	End	Start	End	Start	End	Start	End	Start	End	Start	End	Start	End	Start	End	Start	End		
05-40R	2	4.7	3.6					3.2	1.9	4.1	2.8	5.1	3.7	6.1	4.6						
	4	6	4.6											5.1	3.4	6	4.2	7	5.1		
10-40R	4	8	5	9	6	12	8														
	6	12	7			10	5	12	7	15	10										
	8	16	10							13	6	16	9	18	11						
	10	20	12											16	8	19	10	22	13	27	18
15-40R	4	13	8	18	13	24	18														
	6	20	13			20	12	25	17	30	22										
	8	26	17							26	16	31	21	37	26						
	10	33	21											33	20	38	25	43	30	54	40
20-40R	4	24	15	34	24	43	33														
	6	36	24			36	22	46	31	55	40										
	8	47	31							48	29	57	38	67	48						
	10	59	38									50	27	59	36	69	46	79	55	99	73
25-40R	4	43	26	55	37	72	52														
	6	64	39			59	32	75	47	91	63										
	8	86	53							78	43	94	58	111	73						
	10	107	66											98	53	114	69	130	84	163	115
30-40R	4	69	42	92	62	119	87														
	6	103	63			98	54	125	80	151	105										
	8	138	84							130	72	157	98	184	123						
	10	172	105											163	91	190	116	217	141	270	192
33-40R	4	142	91	171	113	224	163														
	6	213	136			178	96	231	145	283	195										
	8	284	182							238	127	290	177	343	226						
	10	356	227											297	159	350	209	402	258	510	357
35-40R	4	164	105	217	149	281	210														
	6	246	158			228	132	293	193	357	254										
	8	328	210							304	176	369	237	433	298						
	10	410	263											381	220	445	281	509	342	638	463
40-40R	4	281	169	345	219	447	316														
	6	421	253			363	184	465	281	568	377										
	8	562	337							483	245	586	342	689	439						
	10	702	422											604	306	707	403	810	500	1015	694
42-40R	4	496	293	598	372	776	540														
	6	744	439			629	306	807	474	985	642										
	8	992	585							839	408	1017	576	1195	744						
	10	1240	731											1049	510	1227	678	1404	846	1761	1182
45-40	8	690	357	976	607	1242	859														
	12	1035	535			1064	532	1330	785												
	16	1380	714					1152	459	1419	711	1685	962								
	20	1725	892									1507	636	1773	888	2040	1140				
24	2070	1071											1595	562	1861	814	2128	1066	2661	1569	
50-40	8	1090	552	1510	918	1923	1307														
	12	1635	827	1235	403	1647	793	2059	1182												
	16	2180	1103					1783	667	2196	1057	2608	1446								
	20	2725	1379									2332	931	2745	1321	3157	1710				
	24	3270	1654											2469	806	2881	1196	3294	1585	4119	2364

Double Acting Actuators

Working Pressure	8.3 bar (g) Maximum. For higher pressures contact our sales office.
Media	Air or non-corrosive fluid
Temperature range	Standard -20°C to +100°C Low temperature variant -40°C to +85°C* High temperature variant -20°C to +150°C
Operation	Pinion rotates anti-clockwise when the (viewed from) centre chamber supply port A (RHS) is the top) pressurised (see Page 6)

* Please consult Technical Sales for options down to -60°C

Rotation Options

UK Norbro	Nominal 92° total travel including nominal 1° overtravel both clockwise and anti-clockwise.
European Norbro	Nominal 96° total travel including nominal 3° adjustable overtravel and adjustable 10° undertravel both clockwise and anti-clockwise.
Special	180°, 120° - Series 33. For further options consult the Sales Office.

Operating Speeds (Seconds) – Actuator with no load – using Namur Solenoid Control Valve – 5.5 bar (g)

Size-Series	05-40R	10-40R	15-40R	20-40R	25-40R	30-40R	33-40R	35-40R	40-40R	42-40R	45-40	50-40
Double Acting Open and Close	0.1	0.15	0.3	0.5	0.6	1.1	2.1	2.9	3.0	7	8	19
Spring Return Spring Stroke (Closed)	0.1	0.15	0.3	0.5	0.6	1	1.7	2.2	3.5	4.6	6.8	10
Spring Return Air Stroke (Open)	0.1	0.15	0.3	0.5	0.6	1.4	2.7	3.2	4.5	8	12	24

Speeds other than those given above are obtainable if required by using additional control equipment.

NOTE: These times for the actuator are typical and can vary under actual operating conditions.

They are given as a guide only.

Air Consumption per Stroke – Actual Volume – Litres

Size-Series	05-40R	10-40R	15-40R	20-40R	25-40R	30-40R	33-40R	35-40R	40-40R	42-40R	45-40	50-40
Anti-Clockwise	0.05	0.17	0.35	0.69	1.22	1.86	3.39	3.93	6.73	12.0	13.51	23.87
Clockwise (D.A. only)	0.05	0.22	0.39	0.74	1.31	2.05	4.79	5.54	8.19	13.89	20.0	30.5

To obtain Free Air Displacement (FAD) Volume, multiply actual volumes by absolute working pressure, bar (A). The figures in the table above are also the hydraulic volumes.

Weight – Kgs

Size-Series	05-40R	10-40R	15-40R	20-40R	25-40R	30-40R	33-40R	35-40R	40-40R	42-40R	45-40	50-40
Double Acting	0.7	1.3	2.7	4.5	7.4	11.0	22.5	26.0	43.6	71.8	97.0	138.0
Spring Return	0.8	1.6	3.1	5.5	8.4	12.0	26.0	30.0	48.6	80.6	115.0	161.0

Size 05

European and original, Norbro actuator with F03 ISO5211 45° square (F03 DIN3337)

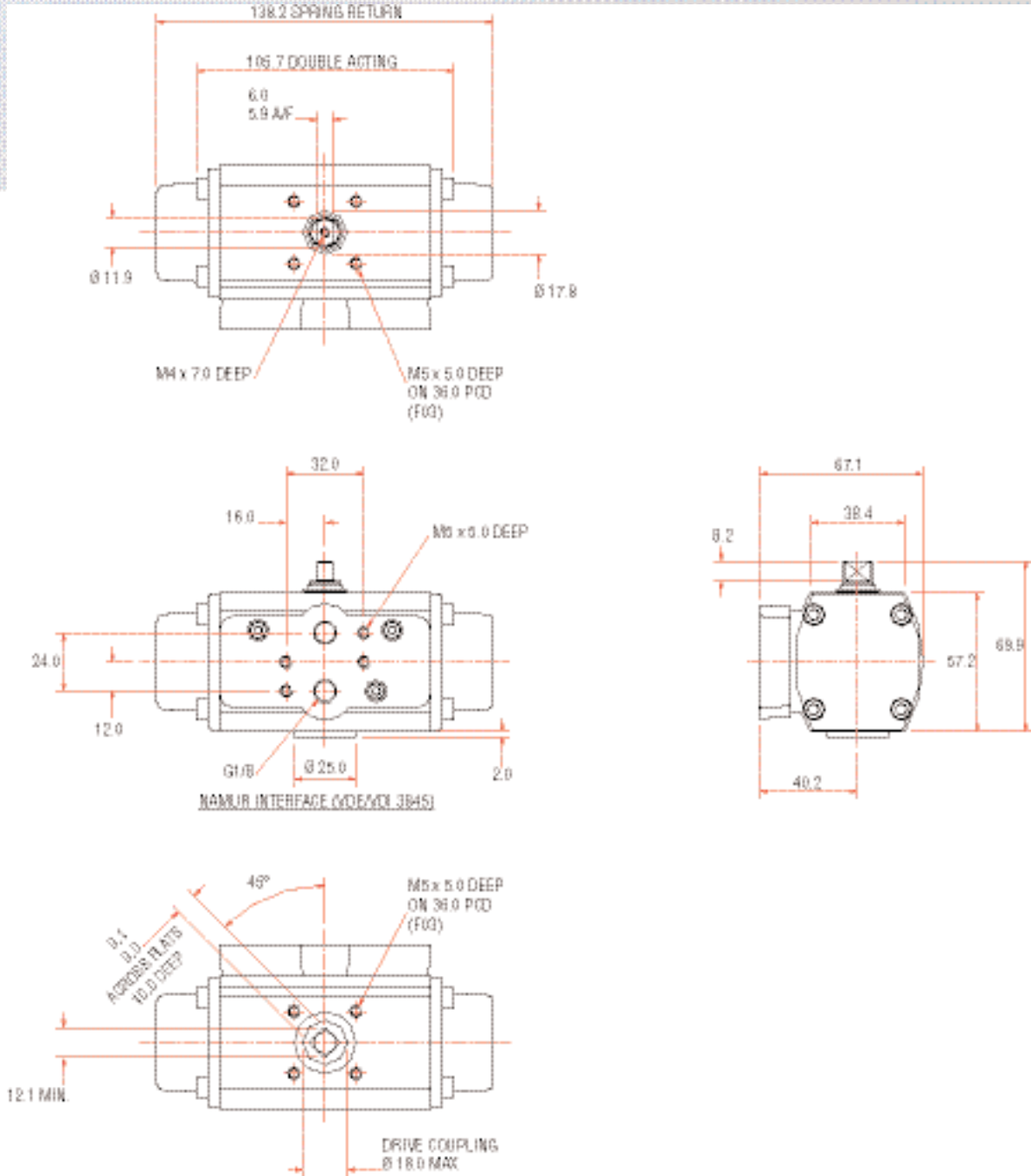

Sizes 10-42

European actuator with ISO5211 45° square (DIN3337)

MAIN TOP ACCESSORY MOUNTING (VDI/VDE 2245)

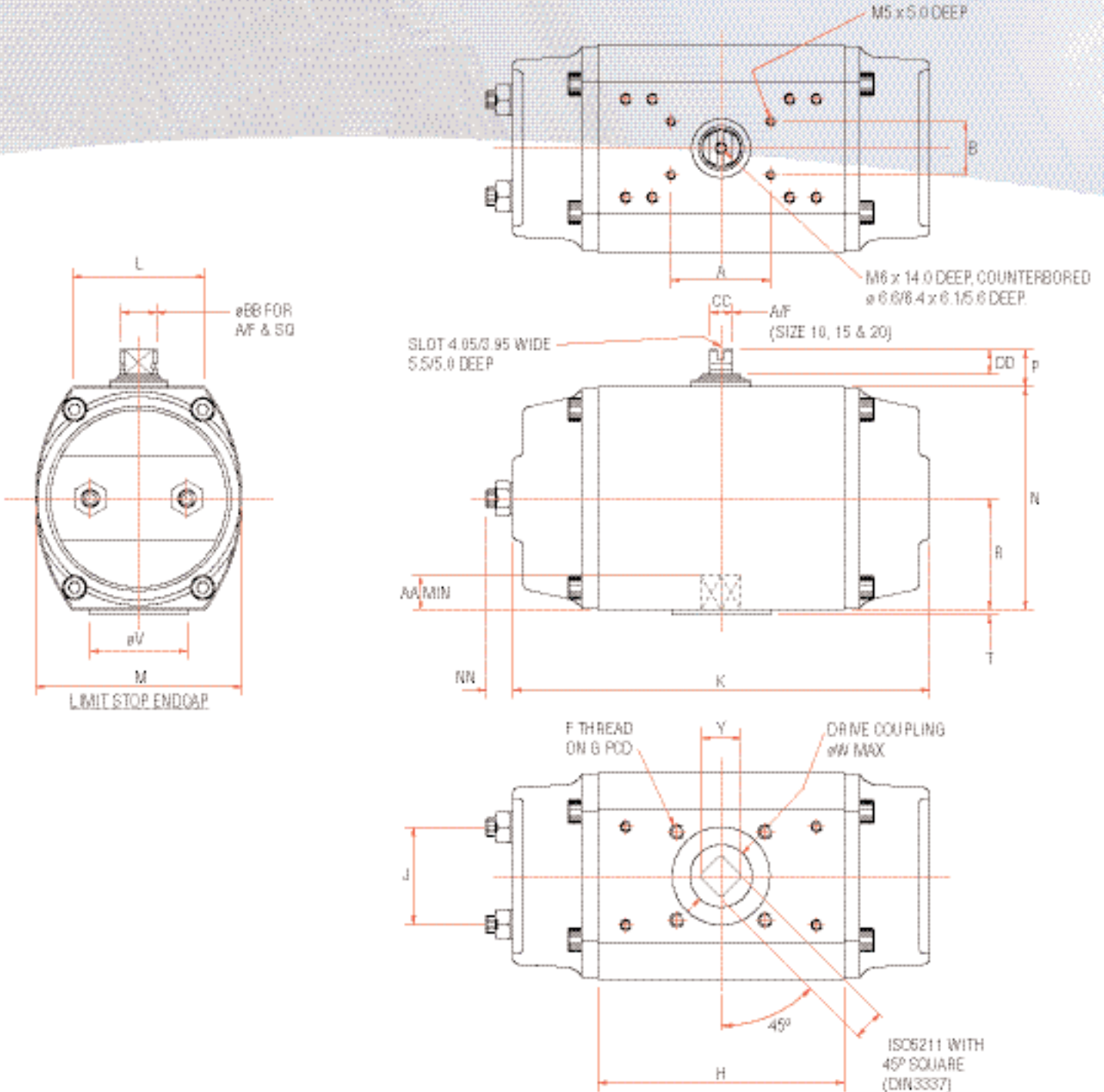

Actuator Size	ISO 5211	A	B	C	D	E	F	G	H	J	K	L	M	N	P	R
10	F04	80.0	30.0	73.0	31.8	M5x5	M5x8	42.0	90.4	43.1	155.3	48.6	76.8	85.5	20.0	42.8
15	F05	80.0	30.0	73.0	31.8	M5x5	M6x9	50.0	114.3	52.0	195.2	55.6	94.0	104.0	20.0	52.0
20	F07	80.0	30.0	107.2	49.2	M6x6	M8x12	70.0	139.7	66.0	235.4	74.3	116.0	125.0	20.0	62.5
25	F07	80.0	30.0	107.2	49.2	M6x9	M8x12	70.0	158.0	78.0	271.0	83.3	135.5	146.6	30.0	73.3
30	F10	80.0	30.0	161.1	73.0	M6x9	M10x15	102.0	190.0	90.0	326.0	100.3	155.0	167.5	30.0	83.8
33	F12	80.0	30.0	161.1	86.0	M8x12	M12x18	125.0	228.0	120.0	398.5	127.0	206.0	214.0	30.0	107.0
35	F12	80.0	30.0	212.8	101.6	M8x12	M12x18	125.0	249.3	123.0	423.9	145.0	213.0	217.0	30.0	108.5
40	F14	130.0	30.0	243.6	117.5	M10x15	M16x24	140.0	297.8	144.0	511.8	137.5	244.9	276.0	50.0	149.0
42	F16	130.0	30.0	-	-	-	M20x30	165.0	363.4	172.0	619.7	165.0	283.0	316.0	50.0	170.0

Sizes 10-42

Original Norbro Pattern with Norbro Square and ISO5211 mounting

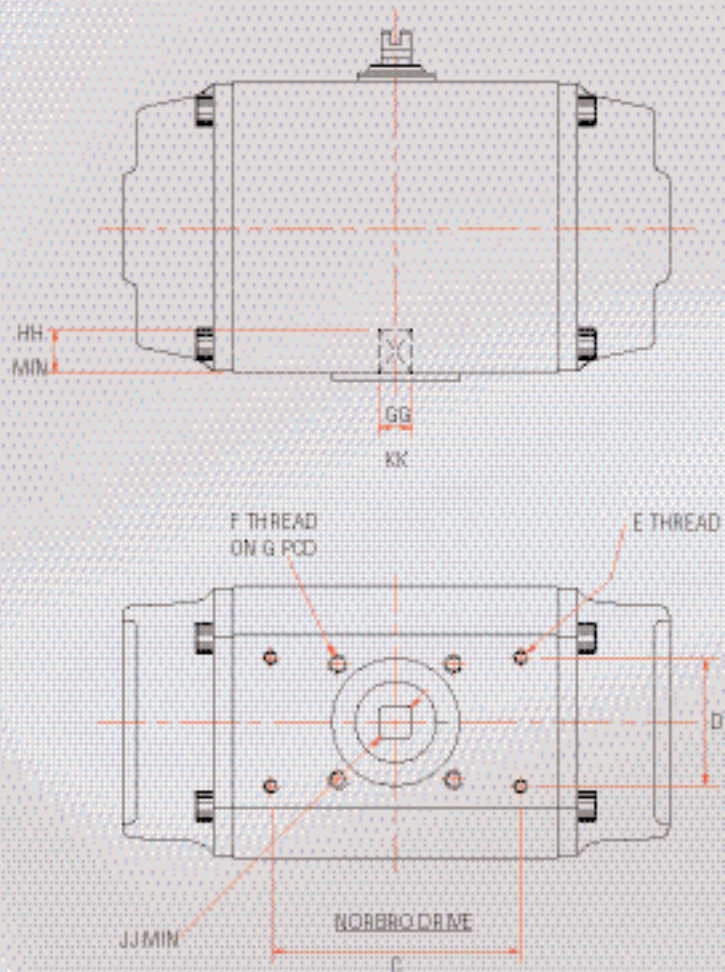
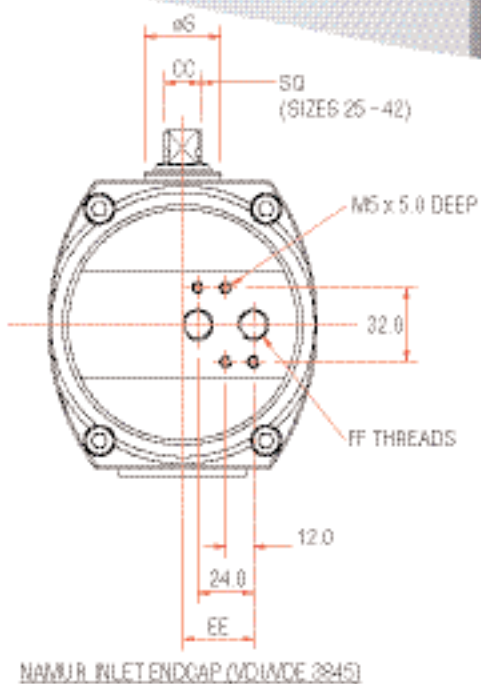

Actuator Size	S	T	V	W	X	Y	AA	BB	CC	DD	EE	FF
10	23.3	3.0	30.0	23.0	11.11/11.00	14.1	12.0	15.0	9.13/9.00	15.2	21.5	G1/8
15	26.0	3.0	35.0	26.0	14.11/14.00	18.1	16.0	16.0	12.70/12.57	13.1	26.0	G1/4
20	33.3	3.0	55.0	33.0	17.11/17.00	22.2	19.0	20.3	12.70/12.57	13.0	30.5	G1/4
25	41.4	3.0	55.0	42.0	17.11/17.00	22.2	19.0	25.1	19.05/18.92	21.2	33.5	G1/4
30	48.2	3.0	70.0	48.0	22.13/22.00	28.2	24.0	28.6	22.23/22.10	20.9	34.5	G1/4
33	52.3	3.0	85.0	55.0	27.13/27.00	36.2	29.0	36.5	28.58/28.45	20.2	45.0	G1/4
35	58.1	3.0	85.0	61.0	27.13/27.00	36.2	29.0	36.5	28.58/28.45	19.9	43.0	G1/4
40	66.5	3.5	100.0	72.0	36.16/36.00	48.2	38.0	45.7	34.93/34.80	37.0	46.6	G1/4
42	88.9	4.0	130.0	90.0	46.16/46.00	60.2	48.0	66.7	50.80/50.67	34.5	58.0	G1/4

Actuator Size	GG	HH	JJ
10	11.23/11.10	15.0	13.8
15	14.40/14.27	19.0	17.8
20	14.40/14.27	19.0	17.8
25	19.18/19.05	27.0	23.8
30	19.18/19.05	27.0	23.8
33	25.53/25.40	33.0	31.8
35	25.53/25.40	33.0	31.8
40	28.70/28.57	40.0	35.8
42	46.16/46.00	50.0	57.6

Sizes 45 & 50

European actuator with ISO5211 45° square (DIN3337)

NAME PLATE TOP ACCESSORY MOUNTING (VDI/VDE 3845)

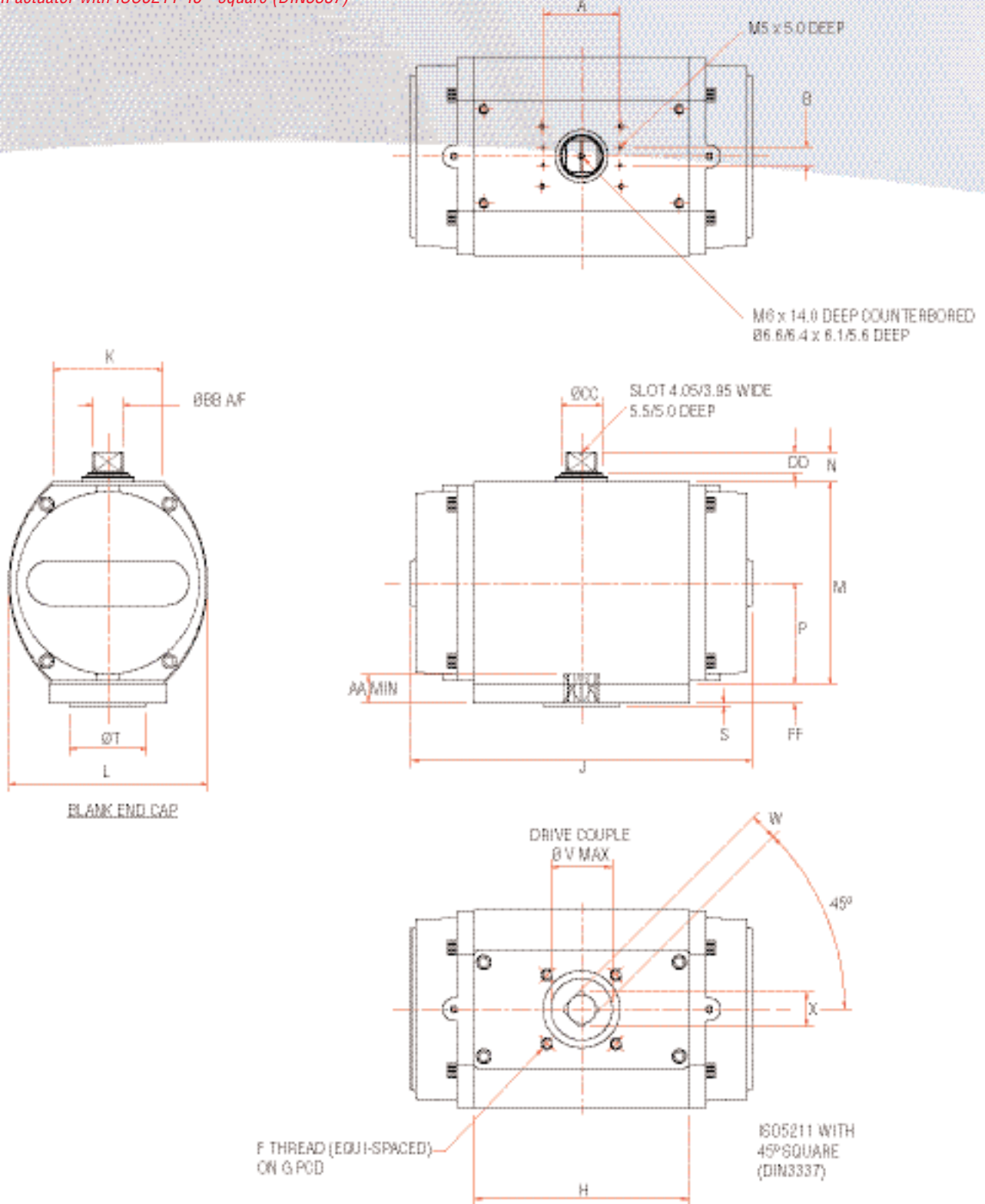

Actuator Size	ISO 5211	A	B	C	D	E	F	G	H	J	K	L	M	N	P
45	F16	130.0	30.0	330.2	158.7	M16x24	M20x30	165.0 (x4 holes)	363.3	575.9	186.1	334.9	341.6	50.0	170.8
50	F25	130.0	30.0	393.7	190.5	M16x24	M16x24	254.0 (x8 holes)	426.1	626.0	226.6	387.5	393.7	50.0	196.8

Sizes 45 & 50

Original Norbro Pattern with Norbro Square and mounting
(Note: has no ISO5211 adaptor plate.)

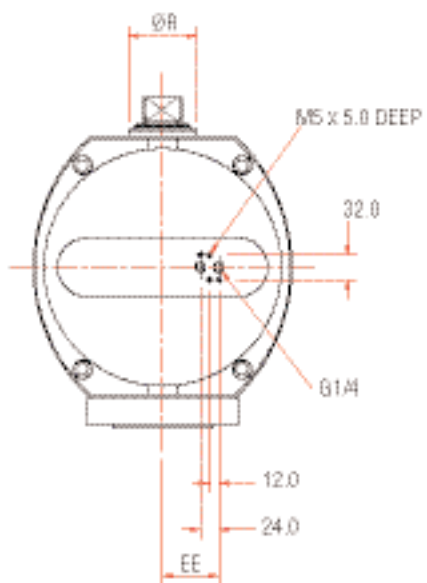

NAMUR INLET ENDCAP (VDI/VDE 3845)

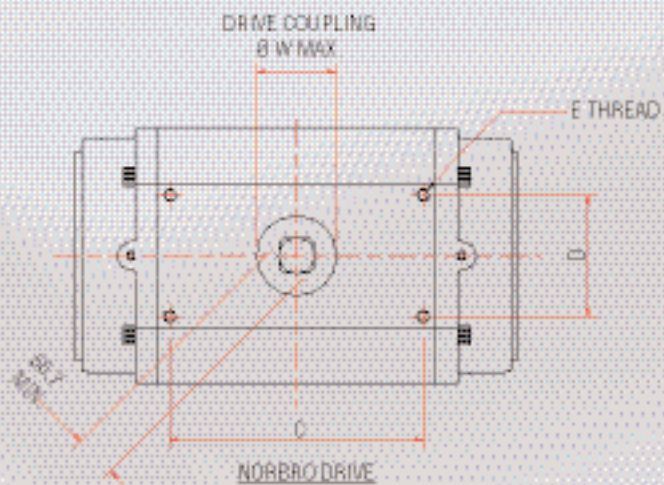
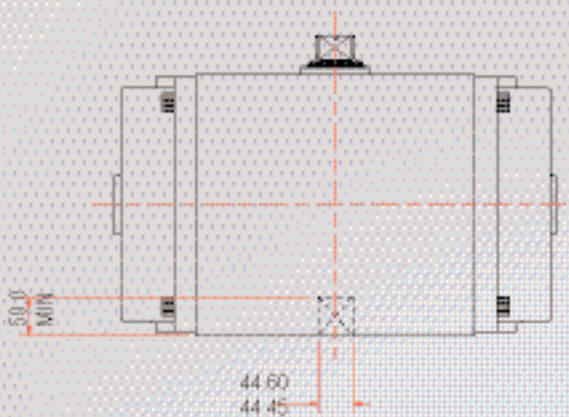

Actuator Size	R	S	T	V	W	X	AA	BB	CC	DD	EE	FF
45	88.9	4.8	130.0	104.0	46.16/46.00	60.2	48.0	50.80/50.67	69.7	34.5	73.0	32.5
50	95.2	4.8	200.0	120.0	55.19/55.00	72.2	57.0	57.15/57.02	76.0	32.8	82.4	30.5

Basic Coding on Norbro 40R Pneumatic Actuators

(For full details of 40R coding and 40 Series coding please contact Technical Sales Office)

1 0 - R D B 4 0 - 1 S D M N 0

Size

05
10
15
20
25
30
33
35
40
42

Operation

A = Double acting
B = 10 springs (4 size 05)
C = 8 springs
D = 6 springs
E = 4 springs
F = 2 springs (05 only)

Temperature

S = Standard
H = High
L = Low

End Cap Options

B = Blank
1 = J switch
M = Limit stops
O = 05 Actuator

Pinion

E = Norbro Drive 0° imperial
N = European diagonal
ISO 5211 45° square drive
(DIN3337)

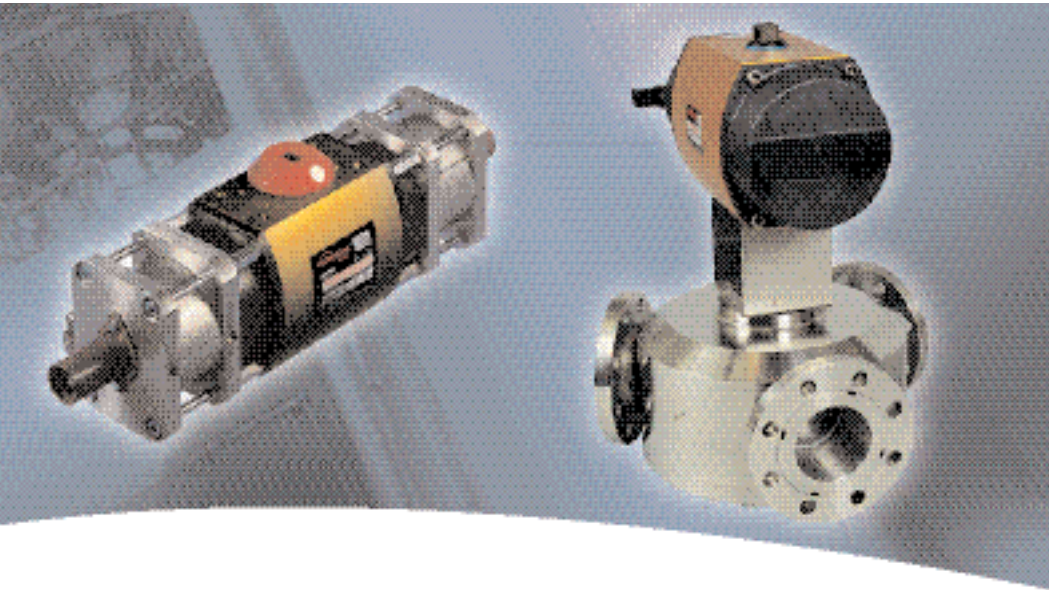

FCD NBEBR0003-01 Printed in Germany. (Replaces PB29 Rev 08/04)

To find your local Flowserve representative:

For more information about Flowserve Corporation,
visit www.flowserve.com or call USA 1 800 225 6989



Variants

- Norbro's Series 61 two-stage actuator is designed for drum filling applications.
- The Series 33 180° actuator provides the perfect solution for Worcester's range of multi-ported valves.

Flowserve Flow Control
A Division of Flowserve GB Ltd
Burrell Road, Haywards Heath
West Sussex RH16 1TL
United Kingdom
Telephone: +44 (0)1444 314400
Telefax: +44 (0)1444 314401
Email: wvukinfo@flowserve.com

Due to continuous development of our product range, we reserve the right to alter the dimensions and information contained in this leaflet as required. Information given in this leaflet is made in good faith and based upon specific testing but does not, however, constitute a guarantee.