



BUSwitch™ with FOUNDATION® Fieldbus Protocol
Installation, Operating and Maintenance Instructions

Flowserve Corporation
Flow Control Division
www.flowserve.com

1350 N. Mountain Springs Parkway
Springville, Utah 84663-3004
Phone: 801 489 8611

1978 Foreman Dr.
Cookeville, TN 38501
Phone: 931 432 4021

BUSwitch™
with
FOUNDATION® Fieldbus Communications Protocol
Installation, Operating and Maintenance
Instructions



BUSwitch™ with FOUNDATION® Fieldbus Protocol Installation, Operating and Maintenance Instructions

Flowserve Corporation
Flow Control Division
www.flowserve.com

1350 N. Mountain Springs Parkway
Springville, Utah 84663-3004
Phone: 801 489 8611

1978 Foreman Dr.
Cookeville, TN 38501
Phone: 931 432 4021

Table of Contents

Introduction	2
Principles of Operation	2
Printed Circuit Board Specifications	3
Start-up Guide	3
Mechanical Installation	4
Lubrication	4
Electrical Connections	5
Adjustment of Switch Cams	6
BUSwitch™ Embedded Software Specs	6
Resource Block	7
Resource Block Parameter Table	7
Transducer Block	9
Pneumatic Actuator Operation	9
Valve Position Monitoring and Reporting	9
Auxiliary Dry Contact Input	10
Odometer	10
Transducer Block Parameter Table	11
DI Function Block Parameter Table	14
DO Function Block Parameter Table	15

Introduction

Flowserve's BUSwitch™ uses the FOUNDATION® Fieldbus communication protocol to operate pneumatic valve actuators and monitor/report their position. BUSwitch™ also provides an odometer and stroke timer to assist in preventative maintenance.

Principles of Operation

BUSwitch™ utilizes two discrete output function blocks (DO-1 and DO-2) to energize piezo or coil actuators, which act as pilots to shift a large capacity spool valve. For spring return and double acting applications with a desired fail position (open or closed) DO-1 is used to operate a single pilot. For applications requiring fail in last position, both DO blocks are used with a "dual coil" pilot configuration.

In dual coil mode, users may choose to de-energize piezo/coil elements after the valve has reached its desired position or may configure the elements to remain energized (factory default)(see "Transducer Block").

Valve position is sensed with two limit switches. BUSwitch™ communicates the state of these limits in the transducer block's SOLENOIDE_CLOSED and SOLENOIDE_OPENED parameters and in the READBACK_D parameters of DO-1 and DO-2.

The transducer block's ODOMETER parameter tracks the number of valve strokes. It may be reset using RESET_ODOMETER.

The transducer block's transition alarm alerts the used if the stroke time exceeds the time in the parameter TIME_OUT, this alarm is also passed to the OUT_D of the DI-1 block.

Two discrete input blocks are factory-configured. DI-1 is a discrete value indicating the stroke exceeded a specific time. DI-2's OUT_D parameter provides a link to an external dry-contact input (terminal P4). This input is jumper-selectable to normally open or normally closed (jumper J1/J2). Common uses for this input include valve packing pressure monitoring.

A 2-wire cable using the FF H1 (31.25 Kbps) protocol provides communication and power to the FF Communication Board. The communications board, switches, and piezo/coil pilots are all connected to an interface board. Two versions of this interface card are available:

- 2-Wire for bus-powered pilot applications. Utilizes ultra-low power piezo pilot valves.
- 4-Wire for externally powered pilot applications. Utilizes a wide range of 24VDC coil pilot valves.

The communications card operates from 9.5 to 32 VDC. BUSwitches are configured to draw 18 mA of current. Current consumption from the fieldbus segment will remain constant whether a piezo/coil actuator is activated or not.



BUSwitch™ with FOUNDATION® Fieldbus Protocol

Installation, Operating and Maintenance Instructions

Flowserve Corporation
Flow Control Division
www.flowserve.com

1350 N. Mountain Springs Parkway
Springville, Utah 84663-3004
Phone: 801 489 8611

1978 Foreman Dr.
Cookeville, TN 38501
Phone: 931 432 4021

Printed Circuit Board Specifications

Power Requirements: Communications Card	
XA0239 Communication Card	Bus powered 9.5-32 VDC at 18 mA
Power requirements: 2-Wire Version	
XA0238 Interface Card Version 2.0	Bus powered by XA0239 Communication Card
Power requirements†: 4-Wire Version	
XA0242 Interface Card	24 VDC • 10 mA quiescent • 510 mA max. with solenoid activated
Temperature	
Operational	-40°F to +185°F (-40°C to +85°C)
Storage	-40°F to +250°F (-40°C to +120°C)

† To operate, an external 24 VDC source must be locally supplied to the interface card.

FOUNDATION® Fieldbus Information

Manufacturer	
ID	0x464C4F (Hex)
Name	46 6C 6F 77 73 65 72 76 65 F l o w s e r v e
Device	
Type	0x5053 (Hex)
ID	464C4F5053:BUSWITCH:xxxxxx Max. length of 32 characters. Characters 21 through 32 are used for board serial number.
Device Descriptions are supplied on included diskette	

Start-up Guide

CAUTION

The BUSwitch™ may cycle during a configuration download. Exercise caution in handling valves that may be stroked during these procedures.

For best results, Flowserve strongly recommends reading this entire document before attempting to configure and commission BUSwitches.

- Following the instructions in "Mechanical Installation," install the BUSwitch™ onto a pneumatic actuator and turn supply air on.
- Following the instructions in "Electrical connections," connect fieldbus and optional dry-contact wiring.
- Referring to control system or configuration system documentation, install BUSwitch™ device description (DD) files onto system hard drive. *Note:* *Readme file on DD floppy contains instructions.*

Note: For Fisher DeltaV systems, the DD files must be copied to a directory or folder named "464C4F" in order for the system to find them.

- Initialize communications with device and bring up the "Live List." BUSwitches have been configured from the factory with an ID of "464C4F5053:BUSWITCH: [serialnumber]" and a default tag of "FLOWSERVE BUSWITCH." Note the serial number.
- Change the BUSwitch™ attribute Device ID to the value noted in step 4 and change the Device Tag to the appropriate value.
- Assign the Tag configuration in step 5.
- BUSwitches are shipped with resource block, transducer block, (2) DO blocks and (2) DI blocks pre-configured unless specially configured by agreement with customer. Refer to the appropriate sections in this manual for the default configuration. Make any desired changes to this configuration and download.

BUSwitch™ with FOUNDATION® Fieldbus Protocol

Installation, Operating and Maintenance Instructions

Flowserve Corporation
Flow Control Division
www.flowserve.com

1350 N. Mountain Springs Parkway
Springville, Utah 84663-3004
Phone: 801 489 8611

1978 Foreman Dr.
Cookeville, TN 38501
Phone: 931 432 4021

- Using the DO-1.OUT_D value parameter (and DO-2.OUT_D for dual coil mode), stroke the valve (Discrete 0 = de-energized; Discrete 1 = energized) and set limit switches, referring to "Adjustment of Switch Cams" section. Circuit board mounted LED's light when switches are tripped.
- This is the minimum configuration to operate the actuator and read valve position. Refer to FOUNDATION® Fieldbus standards for DO and DI blocks to establish more sophisticated control strategies. Refer to the block sections in this manual for more information on BUSwitch™ functionality.

Mechanical Installation

BUSwitch™ Mounting:

- Installation is best performed with Flowserve NAMUR mounting kits. These kits allow direct mounting of the BUSwitch™ shaft to the actuator pinion without a coupler. The NAMUR mounting kits will work with any actuator conforming to the NAMUR standard for accessory mounting hole locations and pinion dimensions. Simply attach the bracket to actuator and BUSwitch™ to the bracket with the included fasteners. The BUSwitch™ shaft features an integral alignment pin that engages the tapped pinion hole. Flowserve also offers a full line of non-NAMUR mounting kits.

Spool and Tubing Configuration:

The following instructions apply to BUSwitch™ configured with integral pilot valves and spool valve. For non-integral pilot/spool valves, follow manufacturer's instructions for piping.

- For spring return actuators, a 4-way spool valve is provided with port #2 plugged. For double acting actuators, the same valve is provided with no plugs. Make sure the correct spool is selected before installing tubing.
- Make sure all air pressure is removed before installing tubing.
- Attach tubing according to Figures 1 or 2 at right, depending upon application. Attach supply tubing to Port 1 and use 3 and 5 for exhaust.

- To prolong actuator life use only clean, dry plant air. Lubricated air is not required, although it is recommended, particularly for high cycle applications.

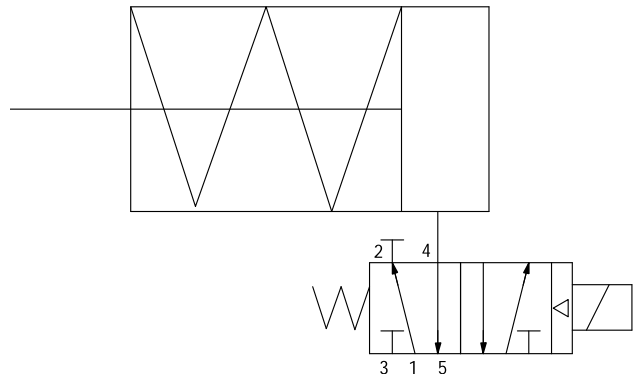

Figure 1

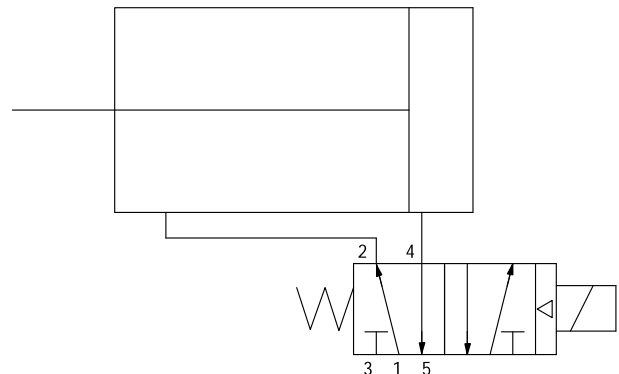

Figure 2

Lubrication

All BUSwitch™ spool valves are pre-lubricated and will operate dry (with no additional lubrication). The use of lubricated air will not interfere with the functioning of the BUSwitch™. If air lubrication is used, the oils listed below are popular, easily obtainable, fluids that are recommended for use with the BUSwitch™ spool valve: Gulf Harmony 47, Mobil DTE Medium, Shell Tellus 29, Texaco Rondo B, Sohivis 47 and Sunnis 921. Many other lubricants are acceptable providing they do not contain detergents that will attack Buna N or Viton Seals.

BUSwitch™ with FOUNDATION® Fieldbus Protocol

Installation, Operating and Maintenance Instructions

Flowserve Corporation
Flow Control Division
www.flowserve.com

1350 N. Mountain Springs Parkway
Springville, Utah 84663-3004
Phone: 801 489 8611

1978 Foreman Dr.
Cookeville, TN 38501
Phone: 931 432 4021

Electrical Connections

CAUTION

To prevent ignition of hazardous atmospheres, keep cover bolts tight while circuits are live. Disconnect supply circuit before opening.

Entry into the BUSSwitch™ housing is made through three 1/2" NPT conduit entries. Figures 3 and 4 provide terminal locations on the interface card.

Connection of the data cable is made to connector P3 – observing polarity. Incorrect polarity will not damage the electronics, but it will prevent communication. For hazardous locations, Underwriters Laboratories (UL) and the National Electric Code (NEC) require an approved sealing fitting within eighteen inches of the switch enclosure. Sealing fittings are not required for Division 2 non-incendive applications.

CAUTION

Make sure power is turned off when making electrical connection. Inadvertent power cycling will result in BUSSwitch™ shutdown. After a power shut-down wait at least five seconds before attempting to turn power back on to assure BUSSwitch™ start-up.

Open conduit entries must be closed after installation using a close-up plug approved for hazardous locations. Conduit and plugs must fully engage five threads.

Terminal P4 is provided for the input of a signal from an external dry-contact switch. Jumper J1 and J2 change the configuration of this input. Factory setting is Normally Closed with DI-2 OUT_D value Discrete 1 = contact open and Discrete 0 = contact closed. Change the jumper setting to “normally open” for Discrete 0 = contact open.

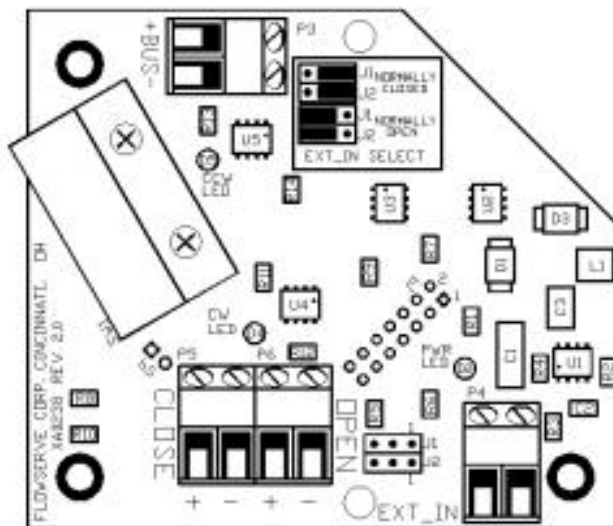

Figure 3
Interface Card: 2-Wire Version XA0238

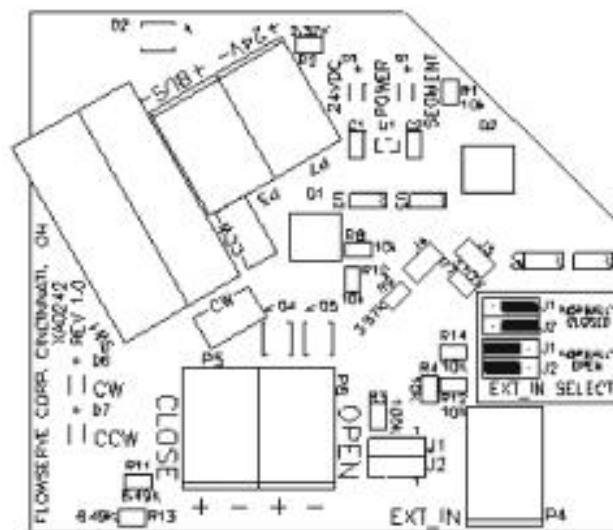

Figure 4
Interface Card: 4-Wire Version XA0242

Special Notes on the fieldbus cabling

Minimum voltage requirement for the BUSwitch™ is 9.5 VDC supply. The output voltage of the fieldbus power supply, the current drawn and the electrical characteristics of the data cable determine the maximum distance that a particular segment can span. With data cable that conforms to the FF cable type 'A' specification, distances of 1900 meters are guaranteed. If a shielded cable is used, connect the shield to ground at **one** point only. Multiple grounds can lead to ground loops which can impair the proper operation of the segment. For this reason, a shield connection has not been provided inside the BUSwitch™ housing. Radio frequency grounding at multiple points through the use of capacitors, allowed by the FF protocols, can be used for increased high frequency EMI (electromagnetic interference) shielding. For a more thorough treatment of data cable wiring and aspects of installation refer to the FOUNDATION® Fieldbus application guide **AG-140: Wiring and Installation 31.25 Kbit/s, Voltage Mode, Wire Medium**. Its reference section lists additional documentation that can be consulted for further information.

Adjustment of Switch Cams

1. Loosen five captive cover screws and remove lid, turning slightly while lifting.
2. Place the actuator in the clock-wise (CW) position and connect to the fieldbus segment.
3. Push down on the top cam until it clears the splined coupler, rotating clockwise until the CW LED is illuminated (Figure 5).
4. Release the cam and insure that it fully engages the spline.
5. Place the actuator in the counter-clockwise (CCW) position.
6. Pull up on the lower cam until it clears its splined coupler, rotating counter-clockwise until the CCW LED is illuminated (Figure 5).

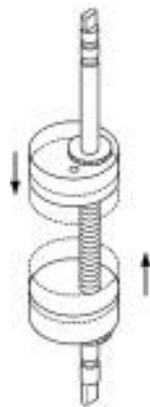

Figure 5

BUSwitch™ Embedded Software Specifications

Flowserve's BUSwitch™ utilizes the SMAR communications stack. Factory-configured embedded software includes the resource block, transducer block, (2) DO blocks and (2) DI blocks. The next sections provide information about each of these blocks. Flowserve assumes the reader has a fundamental understanding of the nature, nomenclature, and geometry of these blocks.

DISCLOSURE

*The Flowserve BUSwitch™ has been certified by FOUNDATION® Fieldbus (FF) to be interoperable in accordance with FF standards. In addition, the BUSwitch™ device has been proven interoperable with Fisher's DeltaV Control System. The term interoperable DOES NOT mean the BUSwitch™ device will behave exactly like other FF-interoperable devices. Because of some flexibility in the interpretation of FF standards, some minor differences exist between many manufacturers. These differences DO NOT affect the **function** of this device.*

Flowserve has disclosed, in an addendum to this document, known issues with individual control systems we have tested. Users and systems integrators should make allowances for these issues. Flowserve will not be responsible for modifying software to change the behavior of the BUSwitch™ relative to these issues.



BUSwitch™ with FOUNDATION® Fieldbus Protocol

Installation, Operating and Maintenance Instructions

Flowserve Corporation
Flow Control Division
www.flowserve.com

1350 N. Mountain Springs Parkway
Springville, Utah 84663-3004
Phone: 801 489 8611

1978 Foreman Dr.
Cookeville, TN 38501
Phone: 931 432 4021

Resource Block

The Resource Block (RB) contains a set of parameters that define characteristics of the physical BUSwitch™ sub-components (function blocks and transducer block). Some of these parameters are considered “operational” because they affect or reflect the operation of function blocks. Others contain more general data about the device.

MANUFAC_ID, DEV_TYPE, DEV_REV, and DD_REV provide information to the control system about which device description to use. All of the RB parameter data is “contained” meaning no links are made to this block. No device configuration data is stored in this block.

General function block operation is reflected in the RB. MODE_BLK may be used to override the Target Modes of all function blocks and transducer block.

Supported Modes (MODE_BLK)

O/S, IMAN, AUTO (Factory default = Auto)

Alarm Types

Standard block alarm plus a discrete alarm for write lock.

Device Initialization

The parameter RESTART permits varying degrees of initialization.

CAUTION

Initializing with the setting “Defaults” will reset the device to the board manufacturer’s defaults, not the Flowserve defaults shown in this document. When using this command, users will have to reestablish all the critical Flowserve factory defaults highlighted in each block section. Items shaded “black” must be configured.

1. Write the value “Defaults” to RESTART.
2. Read the RESTART value. It should equal 1.
3. Turn off and then turn on the device.

Users may utilize the other levels of restart at their discretion.

Resource Block Parameter Table

The following table provides a complete list of all RB parameters. There are no critical default RB parameter settings affected by a “Default” RESTART, however Flowserve recommends setting the MODE_BLK value to “Auto.”

Resource Block Parameter Table

Rel. Index	Parameter	Description
1	ST_REV	The revision level of the static data associated with the function block. To support tracking changes in static parameter attributes, the associated block’s static revision parameter will be incremented each time a static parameter attribute value is written.
2	TAG_DESC	The user description of the intended application of the block.
3	STRATEGY	The strategy field can be used to identify grouping of blocks. This data is not checked or processed by the block.
4	ALERT_KEY	The identification number of the plant unit. This information may be used in the host for sorting alarms, etc.
5	MODE_BLK	The actual, target, permitted, and normal modes of the block.
6	BLOCK_ERR	This parameter reflects the error status associated with the hardware or software components associated with a block. It is a bit string, so that multiple errors may be shown.
7	RS_STATE	State of the function block application state machine.
8	TEST_RW	Read/write test parameter – used only for conformance testing.
9	DD_RESOURCE	String identifying the tag of the resource, which contains the Device Description for this resource.
10	MANUFAC_ID	Manufacturer identification number – used by an interface device to locate the DD file for the resource.



BUSwitch™ with FOUNDATION® Fieldbus Protocol

Installation, Operating and Maintenance Instructions

Flowserve Corporation
Flow Control Division
www.flowserve.com

1350 N. Mountain Springs Parkway
Springville, Utah 84663-3004
Phone: 801 489 8611

1978 Foreman Dr.
Cookeville, TN 38501
Phone: 931 432 4021

Rel. Index	Parameter	Description
11	DEV_TYPE	Manufacturer's model number associated with the resource – used by interface devices to locate the DD file for the resource.
12	DEV_REV	Manufacturer revision number associated with the resource – used by an interface device to locate the DD file for the resource.
13	DD_REV	Revision of the DD associated with the resource – used by an interface device to locate the DD file for the resource.
14	GRANT_DENY	Options for controlling access of host computer and local control panels to operating, tuning and alarm parameters of the block.
15	HARD_TYPES	The types of hardware available as channel numbers.
16	RESTART	Allows a manual restart to be initiated. Several degrees of restart are possible. They are 1: Run, 2: Restart resource, 3: Restart with defaults, and 4: Restart processor.
17	FEATURES	Used to show supported resource block options.
18	FEATURE_SEL	Used to select resource block options.
19	CYCLE_TYPE	Identifies the block execution methods available for this resource.
20	CYCLE_SEL	Used to select the block execution method for this resource.
21	MIN_CYCLE_T	Time duration of the shortest cycle interval of which the resource is capable.
22	MEMORY_SIZE	Available configuration memory in the empty resource. To be checked before attempting a download. MIN_CYCLE_T Time duration of the shortest cycle interval of which the resource is capable.
23	NV_CYCLE_T	Minimum time interval specified by the manufacturer for writing copies of NV parameters to non-volatile memory. Zero means it will never be automatically copied.
24	FREE_SPACE	Percent of memory available for further configuration. Zero in a pre-configured resource.
25	FREE_TIME	Percent of the block processing time that is free to process additional blocks.
26	SHED_RCAS	Time duration at which to give up on computer writes to function block RCAS locations. Shed from RCAS shall never happen when SHED_RCAS = 0.
27	SHED_ROUT	Time duration at which to give up on computer writes to function block ROUT locations. Shed from Rout shall never happen when SHED_ROUT = 0.
28	FAULT_STATE	Condition set by loss of communication to an output block. When FAULT_STATE condition is set the function blocks will perform their FSTATE actions.
29	SET_FSTATE	Allows the FAULT_STATE condition to be manually initiated.
30	CLR_FSTATE	Writing to this parameter will clear the FAULT_STATE condition as long as the problem which initially caused the FAULT_STATE has been cleared.
31	MAX_NOTIFY	Maximum number of unconfirmed notify messages possible.
32	LIM_NOTIFY	Maximum number of unconfirmed alert notify messages allowed.
33	CONFIRM_TIME	The time the resource will wait for confirmation of receipt of a report before trying again. Retry shall not happen when CONFIRM_TIME = 0.
34	WRITE_LOCK	If set, writes to parameters within the device are not allowed, except to clear WRITE_LOCK. Block inputs will continue to be updated.
35	UPDATE_EVT	This alert is generated by any change to the static data.
36	BLOCK_ALM	The block alarm is used for all configuration, hardware, connection failure, or system problems in the block. The cause of the alert is entered in the subcode field.
37	ALARM_SUM	The current alert status, unacknowledged states, unreported states, and disabled states of the alarms associated with the function block.
38	ACK_OPTION	Selection of whether alarms associated with the block will be automatically acknowledged.
39	WRITE_PRI	Priority of the alarm generated by clearing the write lock.
40	WRITE_ALM	This alert is generated if the write lock parameter is cleared.



BUSwitch™ with FOUNDATION® Fieldbus Protocol

Installation, Operating and Maintenance Instructions

Flowserve Corporation
Flow Control Division
www.flowserve.com

1350 N. Mountain Springs Parkway
Springville, Utah 84663-3004
Phone: 801 489 8611

1978 Foreman Dr.
Cookeville, TN 38501
Phone: 931 432 4021

Transducer Block

The Transducer Block (TB) provides the link between standard function blocks (DO-1, DO-2, DI-1, & DI-2) and the sensors and piezo/coil actuators within the BUSwitch™ device. It tracks number of valve strokes. The TB also provides some configuration flexibility.

This section details those parameters affecting the function and configuration of the BUSwitch™ device. **This discussion includes all operational aspects of the function blocks as well.** A complete list of TB parameters follows at the end of the section. Complete function block parameter lists are provided in Appendices A and B.

Pneumatic Actuator Operation – Single Coil, Fail Open or Fail Closed

For operation requiring a consistent fail position (either open or closed), select the “Single Coil” TB.OPERATION parameter. One DO block (DO-1) is used. The TB reads DO-1 OUT_D Value and energizes both the OPEN (P6) and CLOSE (P5) terminals as shown in the Single Coil Truth Table. To reverse the actuator fail mode for double acting actuators, reverse ports 2 and 4. To reverse spring-return actuators, actuator modification is necessary.

Single Coil Truth Table

DO1.OUT_D	OPEN/CLOSE
0	De-energized
1	Energized

When in Auto mode, DO1.OUT_D follows the SP_D Value. If the user wishes to invert the above truth table relative to SP_D, change the function block IO_OPTS parameter to “Invert.” This will energize the coil on an SP_D Discrete 0 and de-energize on an SP_D Discrete 1. This toggle has the same effect when “dual coil” mode is selected; it is necessary to select “Invert” for both DO blocks.

Pneumatic Actuator Operation – Dual Coil, Fail in Last Position

Select the “Dual Coil” TB.OPERATION parameter. Dual Coil Operation uses both DO1.OUT_D and DO2.OUT_D block parameters configured in an interlocking manner. *For valve movement to take place, the OUT_D parameters must take on opposite values as shown in the next table.*

Dual Coil Truth Table

DO1 OUT_D	DO2 OUT_D	OPEN	CLOSE
0	0	No Change	No Change
1	0	Energized	De-energized
1	1	No Change	No Change
0	1	De-energized	Energized

Referring to Figure 2, energizing the “OPEN” terminals will provide air to Port 4 and energizing the “CLOSE” terminals will provide air to Port 2. To reverse the valve operation, either reverse the solenoid valve wires on P5 and P6, or reverse the actuator tubing connections on Port 2 and 4.

The TB.OUTPUT_CONFIGURATION parameter selects whether solenoid pilot elements stay energized or become de-energized after the valve reaches its desired position. If the “Pulse” option is selected, the elements will de-energize after the length of time selected in the TB.TIME_OUT parameter. The “Constant” setting maintains element voltage until new DO-1 and DO-2 OUT_D values are selected.

Valve Position Monitoring and Reporting

The BUSwitch™ TB monitors the status of two limit switches. SW1 is the upper switch and is set to trip when the valve reaches the closed position. SW2 is the lower switch and is set to trip when the valve is open. The TB.SOLENOIDE_CLOSED parameter displays SW1 status as False when not tripped and True when tripped. TB.SOLENOIDE_OPENED parameter displays SW2 status the same way.

The TB provides limit switch status to the READBACK_D parameters of DO-1 and DO-2 respectively per the following truth table.

Truth Table for READBACK_D Values

SW1	SW2	DO-1 RDBK	DO-2 RDBK	Meaning
A	A	1	1	Improper switch adj.
A	O	1	0	Actuator CLOSED
O	A	0	1	Actuator OPENED
O	O	0	0	Actuator is moving

A = Activated or Tripped, O = Open or Not Tripped

FOUNDATION® Fieldbus DO blocks write the READBACK_D value to the PV_D variable within each block. PV_D may then be linked to the BKCAL_OUT variable. Figure 6 shows a schematic of a DO block illustrating this feature.

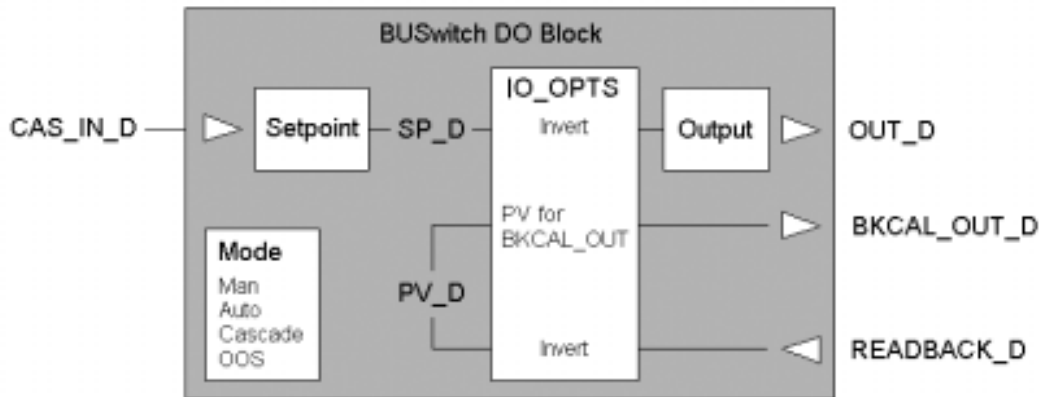

Figure 6 – DO Block Schematic

To link DO.PV_D to DO.BKCAL_OUT, configure the IO_OPTS for the desired block to “PV for BKCAL_OUT.” *Note: This action prevents the use of “Invert” as an IO Option.* Then, link BKCAL_OUT to the BKCAL_IN of the function block sending the CAS_IN_D signal.

Auxiliary Dry Contact Input

The BUSwitch™ TB also monitors continuity across terminals P4. This status is seen in the external alarm parameter and in the OUT_D of DI-2. DI-2.OUT_D will read Discrete 1 when no continuity exists and the “Normally Closed” J1 and J2 jumpers are selected. When contact is made in this jumper mode, the output changes to Discrete 0.

To reverse the outputs, change the J1 and J2 settings to “Normally Open.” Refer to Figures 3 and 4 for the jumper settings.

Odometer Function

TB Parameter ODOMETER reports the number of open-closed and closed-open transitions. It may be reset using the RESET_ODOMETER parameter. Simply write a “True” value to this parameter to reset.

Valve Stroke Time Out Function

The BUSwitch™ times each valve stroke and reports the time from the move command until the appropriate position switch is tripped. The stroke time is displayed in the transducer block parameter “TRANSITION TIME.” If the “TRANSITION TIME” is greater than the value entered in “TIME-OUT,” an alarm is generated. This alarm is displayed in the transducer block parameter “TRANSITION-ALARM” and is also sent to the DI-1 block “OUT-D.” This is a “linkable” input and can be used to alter process control. The alarm will stay present until the “RESET-TIMEOUT” parameter is set to “TRUE” in the transducer block.

Additional TB Parameters

Several TB parameters exist to store information about the valve, actuator and BUSwitch™ device. In addition, calibration information may be stored. Refer to the complete list of BUSwitch™ TB parameters starting on page 11 for a description of these parameters.



BUSwitch™ with FOUNDATION® Fieldbus Protocol

Installation, Operating and Maintenance Instructions

Flowserve Corporation
Flow Control Division
www.flowserve.com

1350 N. Mountain Springs Parkway
Springville, Utah 84663-3004
Phone: 801 489 8611

1978 Foreman Dr.
Cookeville, TN 38501
Phone: 931 432 4021

Transducer Block Parameters

Rel. Index	Parameter	Factory Default	Description
1	ST_REV		The revision level of the static data associated with the function block. To support tracking changes in static parameter attributes, the associated block's static revision parameter will be incremented each time a static parameter attribute value is changed. Also, the associated block's static revision parameter may be incremented if a static parameter attribute is written but the value is not changed.
2	TAG_DESC		The user description of the intended application of the block.
3	STRATEGY		The strategy field can be used to identify grouping of blocks. This data is not checked or processed by the block.
4	ALERT_KEY		The identification number of the plant unit. This information may be used in the host for sorting alarms, etc.
5	MODE_BLK	Auto	The actual, target, permitted, and normal modes of the block.
6	BLOCK_ERR		This parameter reflects the error status associated with the hardware or software components associated with a block. It is a bit string, so that multiple errors may be shown.
7	UPDATE_EVT		This alert is generated by any change to the static data.
8	BLOCK_ALM		The block alarm is used for all configuration, hardware, and connection failure or system problems in the block. The cause of the alert is entered in the sub-code field. The first alert to become active will set the Active status in the Status attribute. As soon as the Unreported status is cleared by the alert reporting task, another block alert may be reported without clearing the Active status, if the sub-code has changed.
9	T_RANSDUCER_DIRECTORY		A directory that specifies the number and starting indices of the transducers in the transducer block.
10	TRANSDUCER_TYPE		Identifies the transducer that follows.
11	XD_ERROR		One of the error codes defined in section 4.8 of the FF-903 document on the XD_ERROR and Block Alarm sub-codes.
12	COLLECTION_DIRECTORY		A directory that specifies the number, starting indices, and DD Item IDs of the data collections in each transducer within a transducer block.
13	FINAL_VALUE_D		The requested valve position and status written by a discrete Function Block.
14	ACT_FAIL_ACTIN		Specifies the final failure position of the actuator as defined in section 4.6 of the FF-903 document on the Actuator Failure Actions.
15	ACT_MAN_ID	4607055	The BUSwitch manufacturer identification number.
16	ACT_MODEL_NUM		The actuator model number.
17	ACT_SN		The actuator serial number.
18	VALVE_MAN_ID		The valve manufacturer identification number.
19	VALVE_MODEL_NUM		The valve model number.
20	VALVE_SN		The valve serial number.
21	VALVE_TYPE		The type of the valve as defined in section 4.7 of the FF-903 document on the Valve Type.
22	XD_CAL_LOC		The location of last calibration.
23	XD_CAL_DATE		Date of the last calibration.
24	XD_CAL_WHO		Name of the person responsible for last calibration.



BUSwitch™ with FOUNDATION® Fieldbus Protocol

Installation, Operating and Maintenance Instructions

Flowserve Corporation
Flow Control Division
www.flowserve.com

1350 N. Mountain Springs Parkway
Springville, Utah 84663-3004
Phone: 801 489 8611

1978 Foreman Dr.
Cookeville, TN 38501
Phone: 931 432 4021

Rel. Index	Parameter	Factory Default	Description
25	OPERATION	Note 1	Configures the piezo/coil element terminals for single coil or dual coil modes.
26	OUTPUT_CONFIGURATION	Note 1	Configures the piezo/coil signals to shut-off or remain continuous after TIME_OUT period. Applies to Dual Coil mode only.
27	ODOMETER		This variable counts the transitions from open to closed and closed to open states. It is reset-able to 0, after maintenance.
28	RESET_ODOMETER		Resets the ODOMETER counter.
29	FAILURE_RECOVERY		Enable/Disable FAILURE_RECOVERY action. 1: Act with or without change in the input, 2: Do not act until a new change in the input.
30	RESET_TIMEOUT		Resets a TIME_OUT occurrence.
31	TRANSITION_TIME		How much time for the last transition.
32	TIME_OUT	10	The time allowed for a transition before the DI associated with the TIME-OUT Alarm is Activated. Also, the length of the One-Shot pulse voltage output to the coils in the Dual Coil Operation Mode.
33	SOLENOIDE_CLOSED		SW1 state
34	SOLENOIDE_OPEND		SW2 state
35	TRANSITION_ALARM		DI1 state = transition TIME-OUT state
36	EXTERNAL_ALARM		DI2 state = It read the status of the Temperature/Pressure Limit (CN1.12 pin) Data is passed on to DI2.
37	ACTION_TIME		Time since last command for transition.

Notes:

1. Selected by Factory in accordance with customer PO specifications.

Transducer Block Parameter Specifications

Rel. Index	Parameter Mnemonic	Data Type	Size	Valid Range	Units	Class
1	ST_REV	Unsigned 16	2	Positive	N/A	Read
2	TAG_DESC	Visible String	32	String Data	N/A	R/W
3	STRATEGY	Unsigned 16	2		N/A	R/W
4	ALERT_KEY	Unsigned 8	1	1-255	N/A	R/W
5	MODE_BLK	DS-69	4		N/A	R/W
6	BLOCK_ERR	Bit String	2		N/A	Read
7	UPDATE_EVT	DS-73	5		N/A	Read
8	BLOCK_ALARM	DS-72	13		N/A	Read
9	TRANSDUCER_DIRECTORY	Unsigned 16 Array	Variable		N/A	Read
10	TRANSDUCER_TYPE	Unsigned 16	2		E	R/W
11	XD_ERROR	Unsigned 8	1		N/A	Read
12	COLLECTION_DIRECTORY	Unsigned 32 Array	Variable		N/A	R/W
13	FINAL_VALUE_D	DS-66	2		N/A	R/W
14	ACT_FAIL_ACTION	Unsigned 8	1	0=Undefined 1=Close 2=Open 3=Last	E	R/W
15	ACT_MAN_ID	Unsigned 32	4		E	R/W



BUSwitch™ with FOUNDATION® Fieldbus Protocol

Installation, Operating and Maintenance Instructions

Flowserve Corporation
Flow Control Division
www.flowserve.com

1350 N. Mountain Springs Parkway
Springville, Utah 84663-3004
Phone: 801 489 8611

1978 Foreman Dr.
Cookeville, TN 38501
Phone: 931 432 4021

Rel. Index	Parameter Mnemonic	Data Type	Size	Valid Range	Units	Class
16	ACT_MODEL_NUM	Visible String	32	String Data	N/A	R/W
17	ACT_SN	Visible String	32	String Data	N/A	R/W
18	VALVE_MAN_ID	Unsigned 32	4		N/A	R/W
19	VALVE_MODEL_NUM	Visible String	32	String Data	N/A	R/W
20	VALVE_SN	Visible String	32	String Data	N/A	R/W
21	VALVE_TYPE	Unsigned 8	1		N/A	R/W
22	XD_CAL_LOC	Visible String	32		N/A	R/W
23	XD_CAL_DATE	Time of Day	7		N/A	R/W
24	XD_CAL_WHO	Visible String	32		N/A	R/W
25	OPERATION	Unsigned 8	1	1=Single 2=Double	N/A	R/W
26	OUTPUT_CONFIGURATION	Unsigned 8	1	1=Pulse 2=Constant	N/A	R/W
27	ODOMETER	Unsigned 32	4		N/A	Read
28	RESET_ODOMETER	Unsigned 8	1	True/False	N/A	R/W
29	FAILURE_RECOVER	Unsigned 8	1	1=Enabled 2=Disabled	N/A	R/W
30	RESET_TIMEOUTS	Unsigned 8	1	True/False	N/A	R/W
31	TRANSITION_TIME	Float	4		Sec.	Read
32	TIME_OUT	Float	4		Sec.	R/W
33	SOLENOIDE_CLOSED	Unsigned 8	1	True/False	N/A	Read
34	SOLENOIDE_OPENED	Unsigned 8	1	True/False	N/A	Read
35	TRANSITION_ALARM	Unsigned 8	1	True/False	N/A	Read
36	EXTERNAL_ALARM	Unsigned 8	1	True/False	N/A	Read
37	ACTION_TIME	Float	4		Sec.	Read

Abbreviations: R/W – Read/Write
Sec. – Seconds



BUSwitch™ with FOUNDATION® Fieldbus Protocol

Installation, Operating and Maintenance Instructions

Flowserve Corporation
Flow Control Division
www.flowserve.com

1350 N. Mountain Springs Parkway
Springville, Utah 84663-3004
Phone: 801 489 8611

1978 Foreman Dr.
Cookeville, TN 38501
Phone: 931 432 4021

Appendix A. Discrete Input Block Parameters

The following table provides a list of all DI block parameters. Critical Factory Default values are highlighted.

Rel. Index	Parameter	Factory Default	Description
1	ST_REV		The revision level of the static data associated with the function block. To support tracking changes in static parameter attributes, the associated block's static revision parameter will be incremented each time a static parameter attribute value is changed. Also, the associated block's static revision parameter may be incremented if a static parameter attribute is written but the value is not changed.
2	TAG_DESC		The user description of the intended application of the block.
3	STRATEGY		The strategy field can be used to identify grouping of blocks. This data is not checked or processed by the block.
4	ALERT_KEY		The identification number of the plant unit. This information may be used in the host for sorting alarms, etc.
5	MODE_BLK	Auto	The actual, target, permitted, and normal modes of the block.
6	BLOCK_ERR		This parameter reflects the error status associated with the hardware or software components associated with a block. It is a bit string, so that multiple errors may be shown.
7	PV_D		Either the primary discrete value for use in executing the function or a process value associated with it. May also be calculated from the READBACK_D value of a DO block.
8	OUT_D		The primary discrete value calculated as a result of executing the function.
9	SIMULATE		Allows the transducer analog input or output to the block to be manually supplied when simulate is enabled. When simulation is disabled, the simulate value and status track the actual value and status.
10	XD_STATE		Index to the text describing the states of a discrete for the value obtained from the transducer.
11	OUT_STATE		Index to the text describing the states of a discrete output.
12	GRANT_DENY		Options for controlling access of host computer and local control panels to operating, tuning and alarm parameters of the block.
13	IO_OPTS		Options which the user may select to alter input and output block processing.
14	STATUS_OPTS		Options which the user may select in the block processing of status.
15	CHANNEL	1 for DI-1 2 for DI-2	The number of the logical hardware channel that is connected to this I/O block. This information defines the transducer to be used going to or from the physical world.
16	PV_FTIME		Time constant of a single exponential filter for the PV, in seconds.
17	FIELD_VAL_D		Raw value of the field device discrete input, with a status reflecting the Transducer condition.
18	UPDATE_EVT		This alert is generated by any change to the static data.
19	BLOCK_ALM		The block alarm is used for all configuration, hardware, and connection failure or system problems in the block. The cause of the alert is entered in the subcode field. The first alert to become active will set the Active status in the Status attribute. As soon as the Unreported status is cleared by the alert reporting task, another block alert may be reported without clearing the Active status, if the subcode has changed.
20	ALARM_SUM		The current alert status, unacknowledged states, unreported states, and disabled states of the alarms associated with the function block.



BUSwitch™ with FOUNDATION® Fieldbus Protocol

Installation, Operating and Maintenance Instructions

Flowserve Corporation
Flow Control Division
www.flowserve.com

1350 N. Mountain Springs Parkway
Springville, Utah 84663-3004
Phone: 801 489 8611

1978 Foreman Dr.
Cookeville, TN 38501
Phone: 931 432 4021

Rel. Index	Parameter	Factory Default	Description
21	ACK_OPTION		Selection of whether alarms associated with the block will be automatically acknowledged.
22	DISC_PRI		Priority of the discrete alarm.
23	DISC_LIM		State of discrete input, which will generate an alarm.
24	DISC_ALM		The status and time stamp associated with the discrete alarm.

Appendix B. Discrete Output Block Parameters

The following table provides a list of all DO block parameters. Critical Factory Default values are highlighted.

Rel. Index	Parameter	Factory Default	Description
1	ST_REV		The revision level of the static data associated with the function block. To support tracking changes in static parameter attributes, the associated block's static revision parameter will be incremented each time a static parameter attribute value is changed. Also, the associated block's static revision parameter may be incremented if a static parameter attribute is written but the value is not changed.
2	TAG_DESC		The user description of the intended application of the block.
3	STRATEGY		The strategy field can be used to identify grouping of blocks. This data is not checked or processed by the block.
4	ALERT_KEY		The identification number of the plant unit. This information may be used in the host for sorting alarms, etc.
5	MODE_BLK	Auto	The actual, target, permitted, and normal modes of the block.
6	BLOCK_ERR		This parameter reflects the error status associated with the hardware or software components associated with a block. It is a bit string, so that multiple errors may be shown.
7	PV_D		Calculated from the READBACK_D value of a DO block, this variable indicates the valve position. It may be linked to BKCAL_OUT and fed back to the sending block.
8	SP_D		The discrete setpoint of this block.
9	OUT_D	0	The primary discrete value calculated as a result of executing the function.
10	SIMULATE_D		Allows the transducer discrete input or output to the block to be manually supplied when simulate is enabled. When simulation is disabled, the simulate value and status track the actual value and status.
11	PV_STATE		Index to the text describing the states of a discrete PV.
12	XD_STATE		Index to the text describing the states of a discrete for the value obtained from the transducer.
13	GRANT_DENY		Options for controlling access of host computer and local control panels to operating, tuning and alarm parameters of the block.
14	IO_OPTS		Options which the user may select to alter input and output block processing.
15	STATUS_OPTS		Options which the user may select in the block processing of status.
16	READBACK_D		This indicates the readback of the actual discrete valve or other actuator position, in the transducer state.
17	CAS_IN_D		This parameter is the remote setpoint value of a discrete block, which must come from another Fieldbus block, or a DCS block through a defined link.



BUSwitch™ with FOUNDATION® Fieldbus Protocol

Installation, Operating and Maintenance Instructions

Flowserve Corporation
Flow Control Division
www.flowserve.com

1350 N. Mountain Springs Parkway
Springville, Utah 84663-3004
Phone: 801 489 8611

1978 Foreman Dr.
Cookeville, TN 38501
Phone: 931 432 4021

18	CHANNEL	1 for DI-1 2 for DI-2	The number of the logical hardware channel that is connected to this I/O block. This information defines the transducer to be used going to or from the physical world.
19	FSTATE_TIME		The time in seconds from detection of fault of the output block remote setpoint to the output action of the block output if the condition still exists.
20	FSTATE_VAL_D		The preset discrete SP_D value to use when fault occurs. This value will be used if the I/O option Fault State to value is selected.
21	BKCAL_OUT_D		The output value and status provided to an upstream discrete block. This information is used to provide bumpless transfer to closed loop control.
22	RCAS_IN_D		Target setpoint and status provided by a supervisory Host to a discrete control or output block.
23	SHED_OPT	***	Defines action to be taken on remote control device timeout.
24	RCAS_OUT_D		Block setpoint and status provided to a supervisory Host for back calculation and to allow action to be taken under limiting conditions or mode change.
25	UPDATE_EVT		This alert is generated by any change to the static data.
26	BLOCK_ALM		The block alarm is used for all configuration, hardware, and connection failure or system problems in the block. The cause of the alert is entered in the subcode field. The first alert to become active will set the Active status in the Status attribute. As soon as the Unreported status is cleared by the alert reporting task, another block alert may be reported without clearing the Active status, if the subcode has changed.

*** = NormalShed_NormalReturn



II 2 G EEx d II T5