

... from development to
implementation

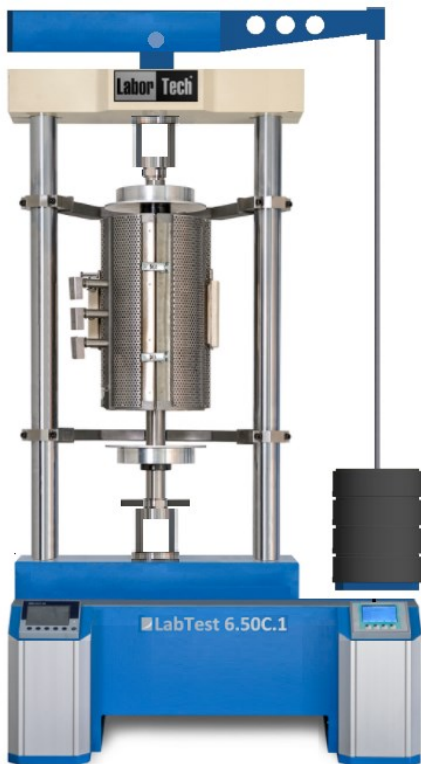

Production of materials testing equipment and automation



Testing machines with lever
mechanism and weight
series **C.1 – CREEPTest 6.10 – 50**

... from development to implementation

all possibilities



Production of materials testing equipment and automation

Testing machines for long-term test - CREEPTest

Reliable, precise with high rigidity and repeatability

The LABORTECH company offers special testing machines for long-term CREEP TEST tests designed to determine creep or stress relaxation in the material. These machines allow tests to be performed at a constant temperature up to 1600 ° C, where the deformation is recorded at specified time intervals. The constant load of these machines is derived from a lever mechanism and weight, a spring mechanism or a special low-speed AC drive with a long service life.

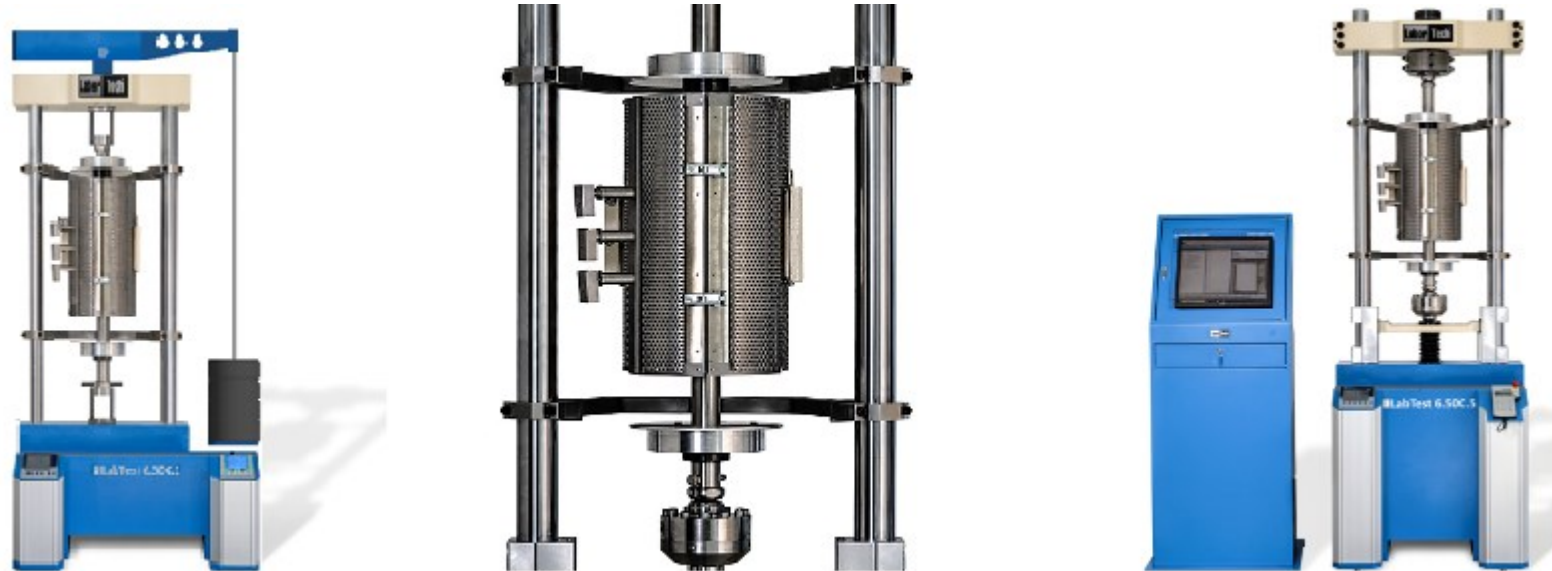

All modifications of CREEP test systems manufactured by us are designed so that the customer can fully rely on its function and accuracy with long-term constant loading (material flow) with force or stress, including elongation and at a constant homogeneous temperature in a high-temperature furnace. Intuitive and trouble-free use of test software designed for long-term tests produced by LABORTECH guarantees you a reliable declaration of results even after 100,000 hours of continuous loading.



Every small detail matters

... from development to
implementation

Labor Tech[®]

Production of materials testing
equipment and automation

Key features of the C.1 series

Precise, coaxiality and durability are the parameters in the standard



The vertical stand design with high rigidity, guaranteed mechanical coaxiality and service life maintains a constant load by means of a **lever mechanism, weights and gravitational force**. Machine construction in accordance with EN ISO 204, ASTM E 292 and ASTM E139, GOST 10145, GOST 3248. The machine includes durable vibration pads to prevent the **transmission of vibrations**.



The Comfort of machine operation on very high level thanks to the SIEMENS LCD display for test control and management and the JUMO LCD display for independent controlling of up to 3 zone high-temperature furnaces, including external thermocouples. Both displays are sensitively integrated into the machine frame, so that they are clear and easy to touch.



The machine is controlled by measuring and control electronics SIEMENS S7-1200 with a maximum sampling frequency of 1000Hz. Resolution level of analog signals $\pm 32,000$ parts. Internal signal processing frequency 200kHz. PC connection - communication via Modbus TCP. Connection of JUMO temperature controller via Modbus RTU.



Based on their concept and construction, LABORTECH machines comply with all the above-mentioned EC directives on machines and equipment. Only state-of-the-art safety techniques and proven industrial components are used that work in accordance with the new safety functions according to ENB ISO 13850-SIL 1 / PL.



Each CREEP machine includes a high-temperature furnace controlled by a JUMO LCD PID regulator, which ensures the accuracy of temperature control in accordance with the EN ISO 6892-2 standard. Depending on the tested material and temperature, high-temperature furnaces operating in the temperature range from 200 ° C to 1600 ° C and can be used with the possibility of using axial extensometers.



The integrated intuitive LOTETest test software provides machine control (gradual release of weights) and data collection with display of measured values from the power channel (if a force sensor is included), the elongation channel and the temperature on the sample as a function of time. CREEPTest software serves as a higher form of data collection, database storage, generate of own methods, etc.



Every small detail matters

... from development to implementation



Production of materials testing equipment and automation

Create your own machine configuration!

Test everything with our wide range of accessories...

A large range of various accessories, including software, will allow you to configure the machine exactly according to your ideas, technical requirements and standards. Just fill out the simple form [HERE](#) and we will send you a price offer immediately. We offer both standard accessories and "tailor-made" accessories.



Clamping and centering jigs designed for long-term tests with jigs for high-temperature furnaces.

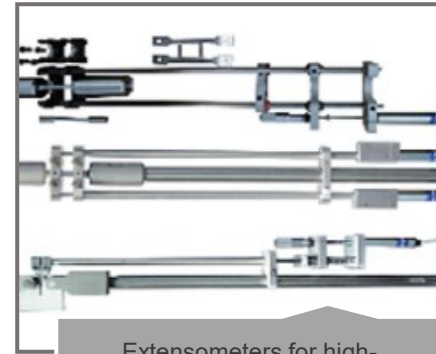

Extensometers for high-temperature furnaces for long-term tests - contact and contactless



High temperature furnaces in the temperature range from 200 to 1600 ° C

Name	Note
EN ISO 204	
ASTM E 292	
ASTM E139	
GOST 10145	
GOST 3248	

CREEPTest software supplied by LABORTECH with various test modules.



Every small detail matters

... from development to implementation



Production of materials testing equipment and automation

Software CREEPTest

Higher form of software for long-term tests with great endurance...

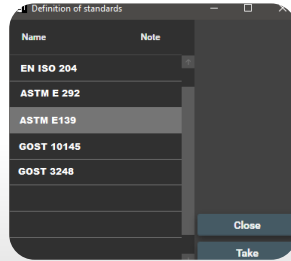

Features of software CREEPTest – BASIC

CREEPTest - BASIC will help you increase reliability and quality during long-term testing in your test rooms and testing laboratories. Software designed for long-term CREEP tests with full automation of the test process and elimination of errors during long-term tests according to EN, ISO, ASTM and GOST standards.

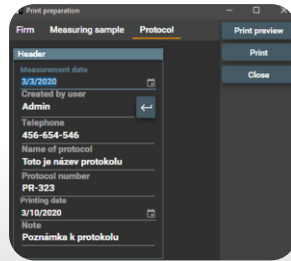

- Simple and intuitive operation, continuous data collection from multiple stations of the C.1 and C.2 series
- Digital display of all current values.
- Remote monitoring of the testing process, statistical processing of results and analysis of tests, database storage of results, data backup
- Saving of measured data in a database with the possibility of filtering

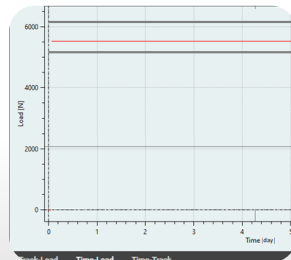

- Modules for long - term tests, determination of creep, stress relaxation in material, Andrade creep test at constant real stress during uniform deformation of test specimen, fracture time depending on deformation and time, Sherby - Dorn parameter, etc.
- Automatic control, including temperature records during long-term tests
- Multilingual version (ČJ, EN, POL, RU, ESP atd.)
- Data export to CSV - BASIS, or to MYSQL and MS SQL
- Unlimited license

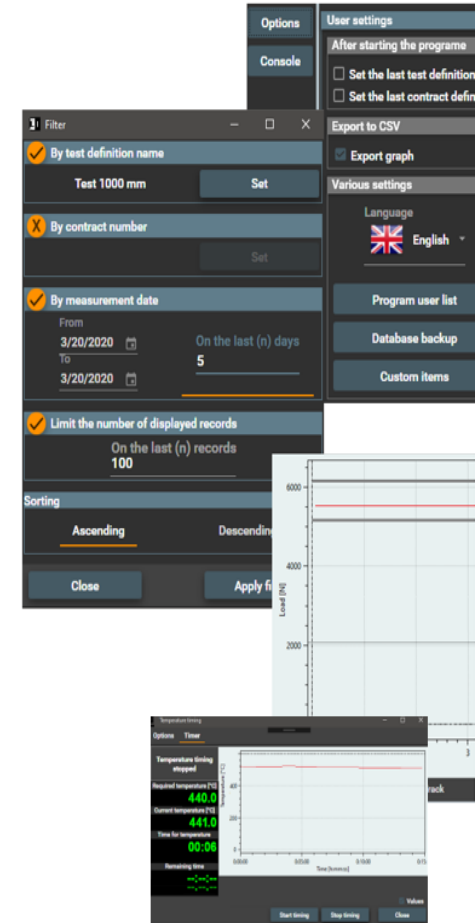

Every small detail matters

... from development to implementation



Production of materials testing equipment and automation



Every small detail matters

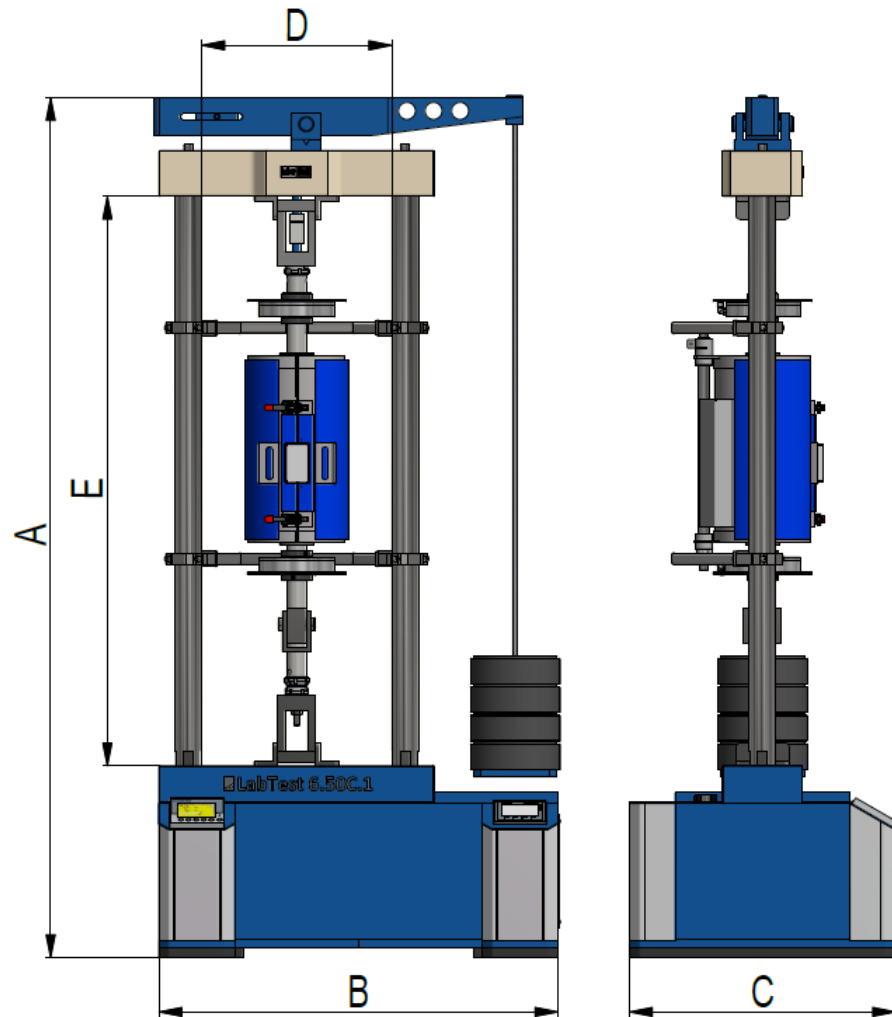

C.1 series – with lever mechanism and weight

Technical data	Unit	6.10C.1	6.30C.1	6.50C.1
Product ordering code		1.03010420	1.03010019	1.03010119
Maximum load	kN	10	30	50
Lever arm ration		1:25	1:25	1:25
Machine dimensions				
Machine height - A	mm	2225	2265	2265
Machine width - B	mm	1050	1050	1050
Machine depth - C	mm	700	700	700
Height of the working space - E*	mm	1500	1500	1500
Width of the working space - D	mm	520	500	500
Machine weight	kg	657	685	685
Measurement accuracy				
Accuracy class 1 according ISO 7500-2		4 up to 100% nominal load		
Electrical connection				
Supply voltage / frequency	V/Hz	230 / 50-60	230 / 50-60	230 / 50-60
Number of phases		1Ph/N/E	1Ph/N/E	1Ph/N/E
Power consumption	VA	60	60	60
Power consumption with high temperature furnace	VA	3500	3500	3500
Environmental conditions				
Working environment temperature	°C	+10 ... +35	+10 ... +35	+10 ... +35
Storage temperature	°C	-25 ... +55	-25 ... +55	-25 ... +55
Humidity of the working environment	%	<90	<90	<90
Others				
Color combination	RAL	1015, 5015	1015, 5015	1015, 5015

Technical changes reserved during development, machine parameters at room temperature, * without testing fixtures

... from development to implementation



Production of materials testing equipment and automation

Technical specifications C.1 series

What else you have to know...



Security

The safety corresponds to the European safety of machines CE directives (89/392 / EEC and 91/368 / EEC - safety of machinery EN60204-1: 1992). The emergency stop function electrically interrupts the drive of the hydraulic power unit and the entire machine. All safety systems are dual-circuit and fail-safe.



Minimum PC configuration requirements for CREEPTest software.

PC-Standard - Processor: min. two cores, min. 2.5 GHz, RAM: min. 4GB, Hard drive: HDD min. 500GB or SSD min. 120GB, Graphics card: integrated in the processor, network connector: min. 2x, Drive: DVD RW, keyboard, mouse, min. 2x USB 3.0, operating system: MS Windows 10 Pro

Monitor-Standard - LCD monitor, 1920x1080 resolution and higher



Servis

STANDARD servis - Our testing machines can work 24 hours a day, 7 days a week, 365 days a year. We provide you with On-line service at all times with our qualified application and service technicians on the telephone line +420 602 527 577.

LABWEBservis - Telephone service using remote access provided by LABORTECH employees. Up to 10 minutes FREE, further according to the LABORTECH price list

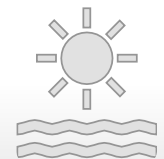

Environmental and operating conditions

Power voltage - Guaranteed reliable operation of our machines is possible with the usual deviations (supply voltage $\pm 10\%$, frequency $\pm 1\%$, ie 230V - 1f or 400V - 3f).

Electromagnetic compatibility (EMC) - Our test systems are designed in accordance with the applicable EMC directives.

Environment - It is necessary to observe the range of working temperatures and humidity according to the manufacturer's recommendations to secure the machine against corrosion, shocks, vibrations, oscillations, etc.



Every small detail matters

... from development to
implementation

all boss corners
radius 0,125"

Labor Tech[®]

Production of materials testing
equipment and automation

checked and approved
laboratory equipment
with ISO 9001:2015
certification



Every small detail matters

LABORTECH in the world

Where to find LABORTECH representations...



Contact:

LABORTECH s.r.o.

Rolnická 130a, 747 05 OPAVA, Česká republika
Telephone: +420 553 731 956, +420 553 668 648
E-mail: info@labortech.cz
Web: www.labortech.cz
GPS: 49°57'05.1"N
17°54'04.4"E

LABORTECH TRADING s.r.o.

Areál VVÚD Praha, Na Florenci 1686/9, 111 71 PRAHA 1, Česká republika
Telephone: +420 731 656 723, +420 724 020 052
E-mail: trading@labortech.cz
Web: www.labortech.eu